

Rear Outer Wheelhouse Replacement (Section)

Removal Procedure

Caution: Refer to [Approved Equipment for Collision Repair Caution](#) in Cautions and Notices.

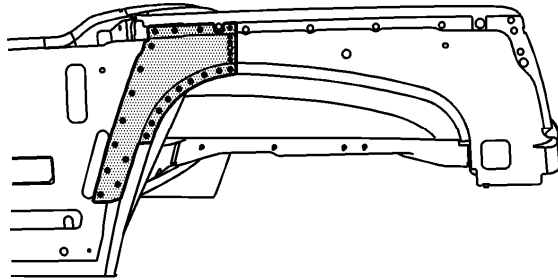

Important: Sectioning procedures have been developed to simplify the replacement of the outer body side panel. If the damage is less severe, use the wheelhouse sectioning procedure when replacing either the rear section of the outer body side panel or the entire panel.

1. Disable the SIR system. Refer to [SIR Disabling and Enabling](#) in SIR.
2. Disconnect the negative battery cable. Refer to [Battery Negative Cable Disconnection and Connection](#) in Engine Electrical.
3. Remove all related panels and components including the outer quarter panel and the lock pillar gusset. Refer to [Quarter Outer Panel Replacement](#) and to [Lock Pillar Gusset Replacement - Rear Compartment](#) .

4. Repair as much of the damage as possible to factory specifications. Refer to Rear Cargo Compartment in [Dimensions - Body](#) .

Caution: Refer to [Foam Sound Deadeners Caution](#) in Cautions and Notices.

5. Note the location and remove the sealers and anti-corrosion materials from the repair area, as necessary. Refer to [Anti-Corrosion Treatment and Repair](#) in Paint and Coatings.

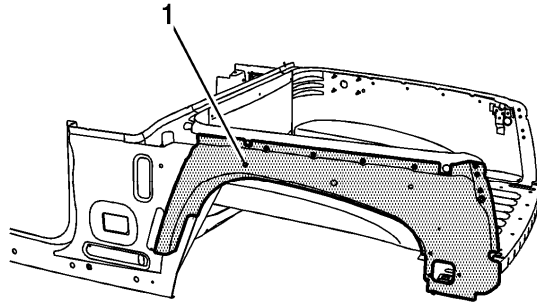

6. Locate the 15 mm (5/8 in) hole (1) in the wheelhouse as shown.

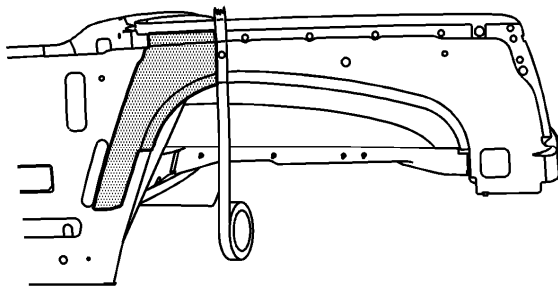

Important: Line up the masking tape vertically along the front edge of the hole as shown.

7. Apply masking tape over the hole and along the entire sectioning location.

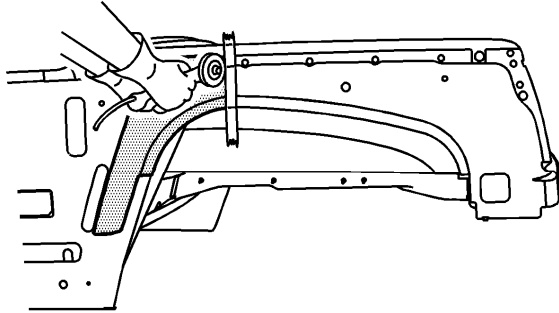

Important: The tape edge facing the front of the vehicle is the proper cut location.

8. Cut the wheelhouse along the front edge of the tape using a cut-off wheel or equivalent.

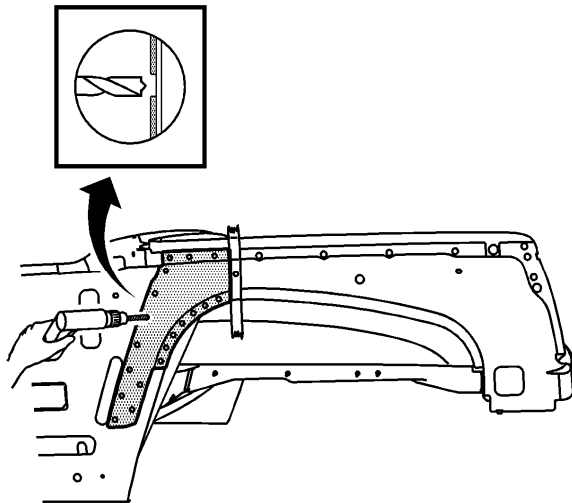

Important: Do NOT damage any inner panels or reinforcements.

9. Locate and drill out all factory welds in front of the sectioning location. Note the number and location of the welds for installation of the front wheelhouse section.

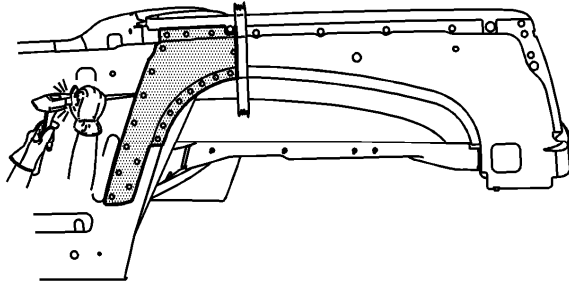

10. Verify the existence of structural weld-through adhesive. Refer to [Structure Adhesive - Identification](#) . If necessary use a chisel to separate the upper fender rail section from the adjacent panels.

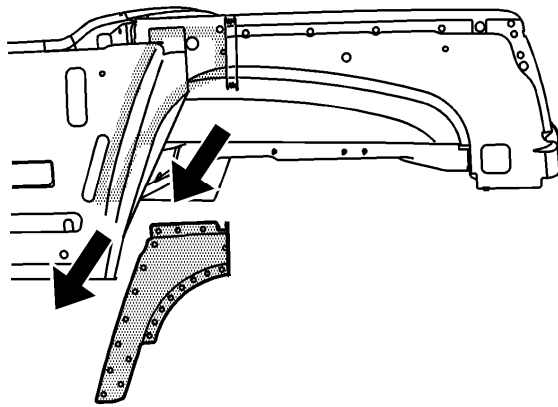

11. Remove the front wheelhouse section.

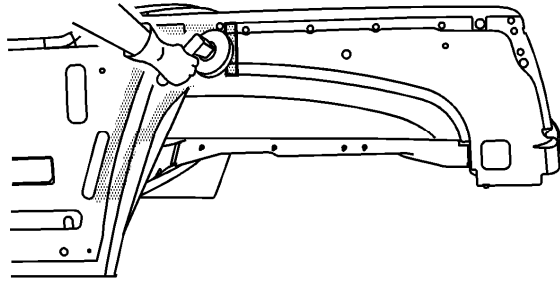

12. Remove the masking tape and grind to bare metal a 25 mm (1 in) strip at the sectioning location.

Installation Procedure

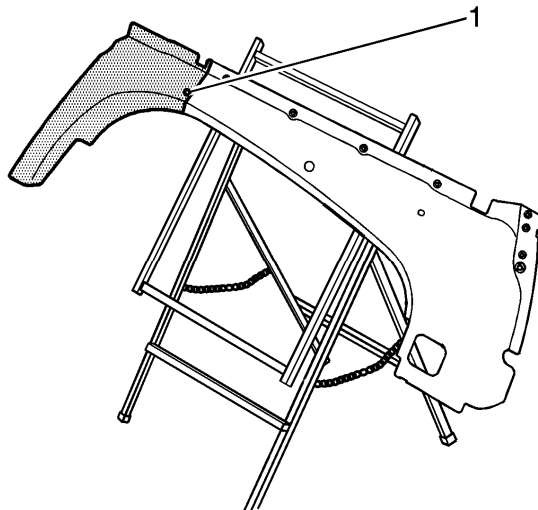

1. On the service wheelhouse panel, locate the 15 mm (5/8 in) hole (1).

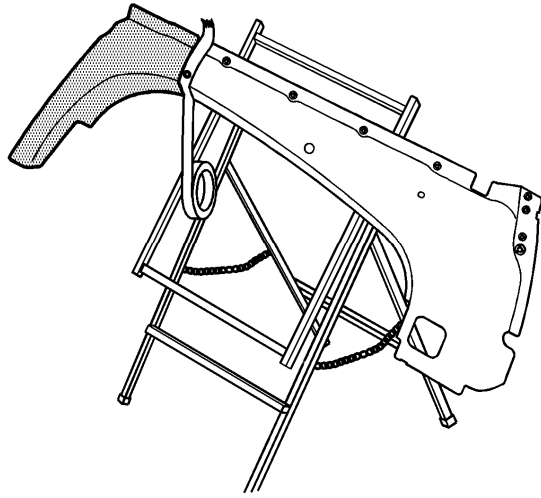

Important: Line up the masking tape vertically along the front edge of the hole as shown.

2. Apply masking tape over the hole and along the entire sectioning location.

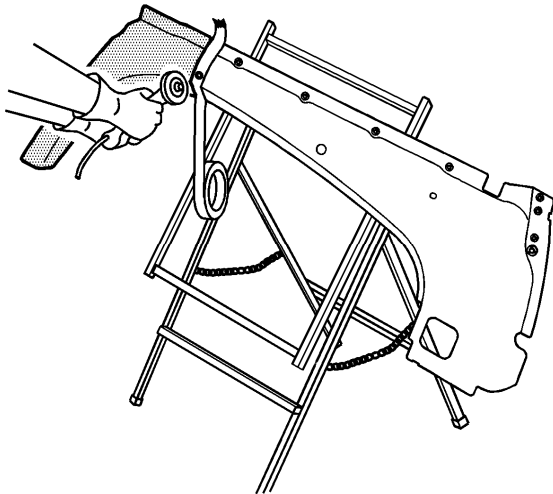

Important: The proper cut location is found along the tape edge facing the rear of the vehicle.

3. Cut the upper fender rail along the back edge of the tape using a cut-off wheel or equivalent.

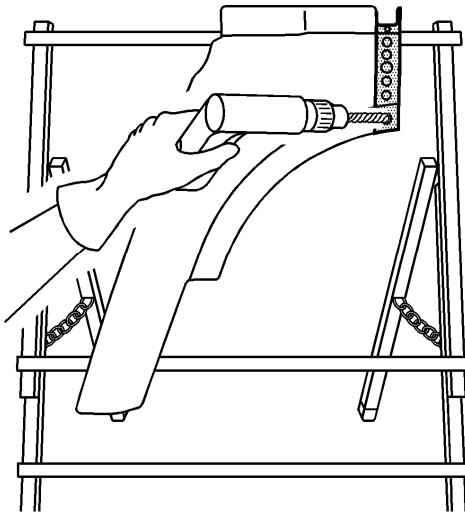

4. Drill 8 mm (5/16 in) plug weld holes along the sectioning cut. Locate these holes 13 mm (½ in) from the edge and spaced approximately 26 mm (1 in) apart.

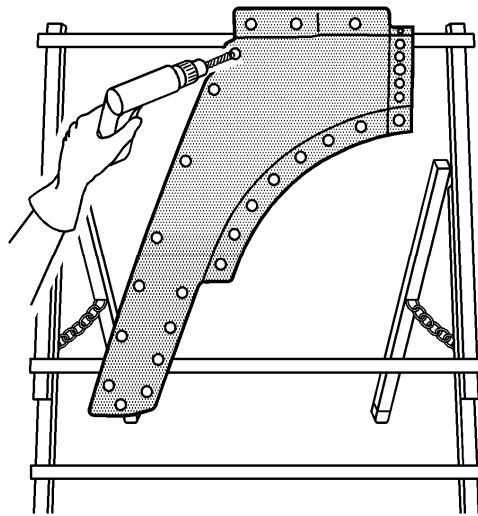

5. Drill 8 mm (5/16 in) plug weld holes in the service part as necessary in locations noted from the original panel.
6. Replace the structural adhesive with an additional plug weld between the existing plug welds, where necessary.
7. Prepare all mating surfaces as necessary.
8. Apply GM-approved Weld-Thru Coating or equivalent to all mating surfaces. Refer to [Anti-Corrosion Treatment and Repair](#) .

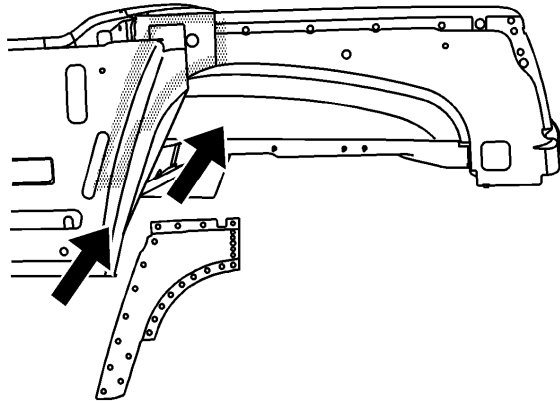

9. Position the front wheelhouse section. Refer to Rear Cargo Compartment section in [Dimensions - Body](#).

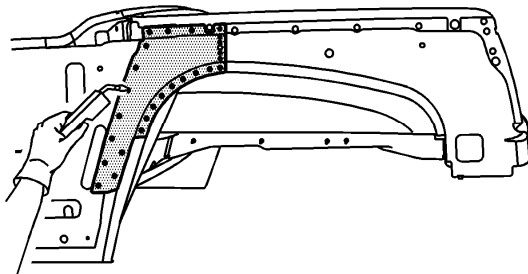

10. Plug weld accordingly.
11. Clean and prepare all welded surfaces.
12. Apply the sealers and anti-corrosion materials to the repair area, as necessary. Refer to [Anti-Corrosion Treatment and Repair](#) in Paint and Coatings.
13. Paint the repair area. Refer to [Basecoat/Clearcoat Paint Systems](#) in Paint and Coatings.
14. Install all related panels and components.
15. Connect the negative battery cable. Refer to [Battery Negative Cable Disconnection and Connection](#) in Engine Electrical.
16. Enable the SIR system. Refer to [SIR Disabling and Enabling](#) in SIR.