

# Upper Rail Replacement

## Removal Procedure

**Caution:** Refer to [Approved Equipment for Collision Repair Caution](#) in Cautions and Notices.

1. Disable the SIR system. Refer to [SIR Disabling and Enabling](#).
2. Disconnect the negative battery cable. Refer to [Battery Negative Cable Disconnection and Connection](#).

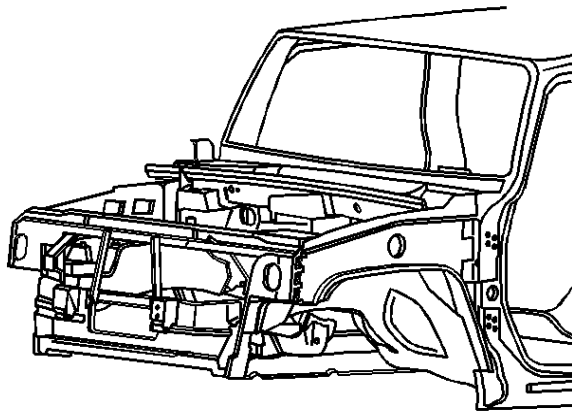

3. Remove all related panels and components.
4. Restore as much of the damage as possible to factory specifications. Refer to [Dimensions - Body](#).

**Caution:** Refer to [Foam Sound Deadeners Caution](#) in Cautions and Notices.

5. Note the location and remove the sealers and anti-corrosion materials from the repair area, as necessary. Refer to [Anti-Corrosion Treatment and Repair](#).

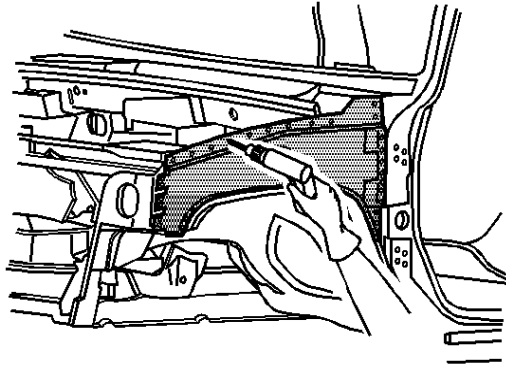

**Important:** Do not damage any inner panels or reinforcements.

6. Locate and drill out all factory welds. Note the number and location of the welds for installation of the front upper rail.

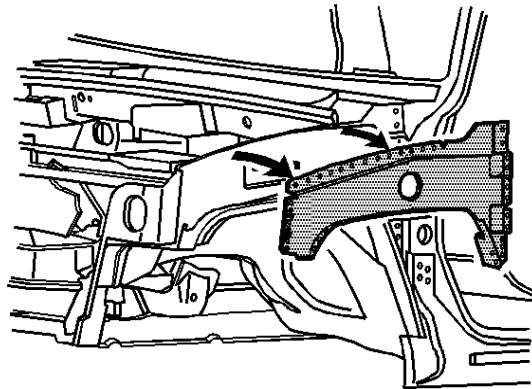

7. Remove the damaged front upper rail.

## Installation Procedure

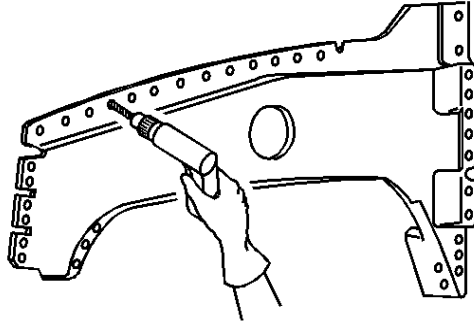

**Important:** In any area damaged beyond recognition, or if structural weld thru adhesive is present, space the plug weld holes 40 mm (1½ in) apart.

1. Drill 8 mm (5/16 in) plug weld holes in the service part as necessary in the locations noted from the original panel.
2. Prepare all attachment surfaces as necessary.

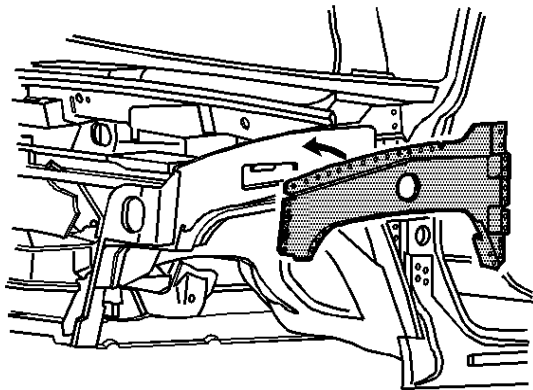

3. Apply GM-approved weld thru coating or equivalent to all mating surfaces. Refer to [Anti-Corrosion Treatment and Repair](#).
4. Position the front upper rail.

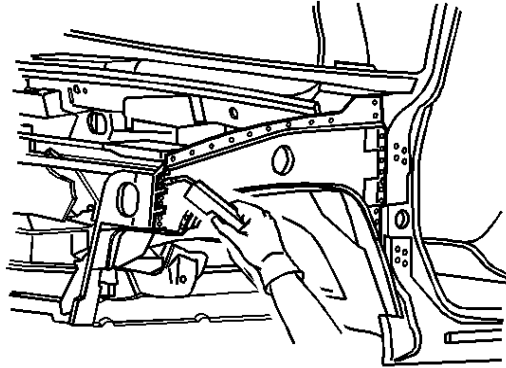

5. Plug weld accordingly.
  6. Clean and prepare all welded surfaces.
  7. Apply the sealers and anti-corrosion materials to the repair area, as necessary. Refer to [Anti-Corrosion Treatment and Repair](#).
  8. Paint the repair area. Refer to [Basecoat/Clearcoat Paint Systems](#).
  9. Install all related panels and components.
  10. Connect the negative battery cable. Refer to [Battery Negative Cable Disconnection and Connection](#).
  11. Enable the SIR system. Refer to [SIR Disabling and Enabling](#).
-