

# Front Hinge Pillar Sectioning

## Removal Procedure

**Important:** Section in specified areas only. Sectioning outside of these areas may compromise the structural integrity of the vehicle. The door frame can be replaced at factory seams, but requires the removal of the windshield and the roof. The sectioning procedures have been developed as a more cost-effective alternative to complete replacement. The specific area to be sectioned is determined by the extent of the damage to the vehicle.

**Important:** When replacing panels that involve servicing of stationary glass, refer to [Urethane Adhesive Installation of Stationary Windows](#) in Stationary Windows before performing any priming or refinishing.

1. Disable the SIR system. Refer to [SIR Disabling and Enabling](#) in SIR.
2. Disconnect the negative battery cable. Refer to [Battery Negative Cable Disconnection and Connection](#) in Engine Electrical.

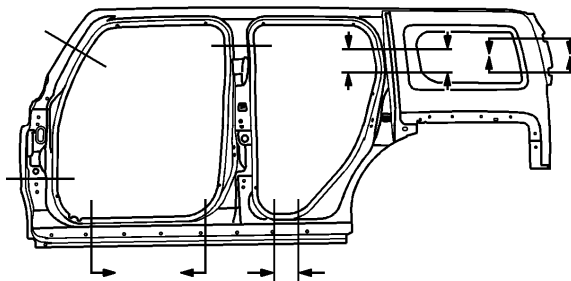

3. Remove all related panels and components.
4. Repair as much of the damage as possible to factory specifications. Refer to [Dimensions - Body](#).

**Caution: Foam sound deadeners must be removed from areas within 152.4 mm (6 in) of where flame is to be used for body repairs. When reinstalling foam sound deadeners, avoid inhaling fumes as bodily injury may result.**

5. Note the location and remove the sealers and anti-corrosion materials from the repair area, as necessary. Refer to [Anti-Corrosion Treatment and Repair in Paint/Coatings](#).

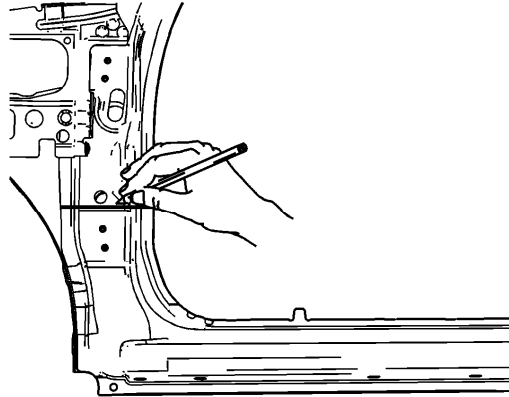

6. On the original outer door frame, measure down from the lower edge of the hole 10 mm (3/8 in) and mark a horizontal line.

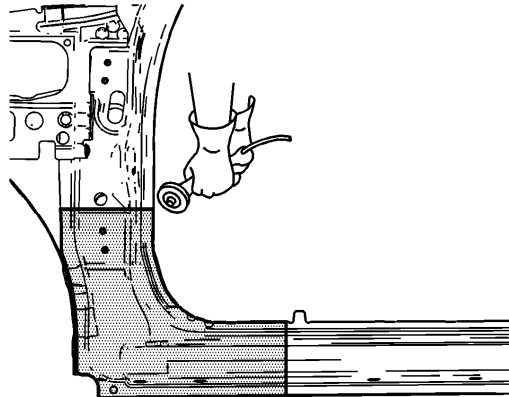

**Important: Do NOT damage any inner panels or reinforcements.**

7. Cut the panel where sectioning is to be performed.
8. Perform additional sectioning procedures as needed.

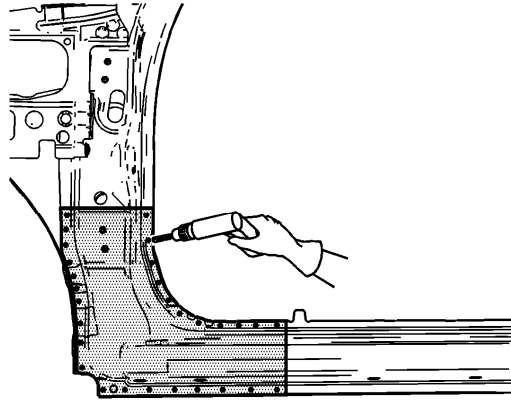

9. Locate and drill out all factory welds. Note the number and location of the welds for installations of the service part.
10. Remove the damaged hinge pillar section.

### Installation Procedure

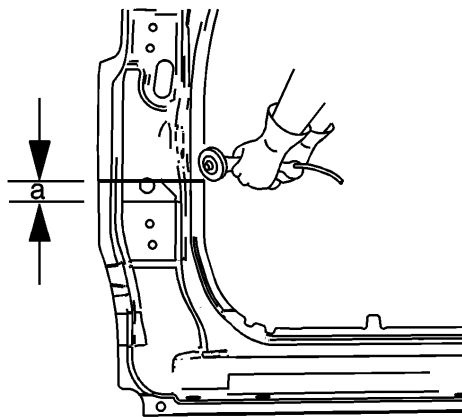

1. On the replacement service part, measure 40 mm (1½ in) upwards from the body line (a) and cut part.

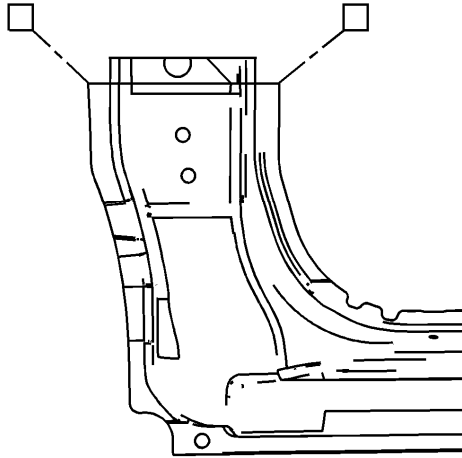

2. Cut and remove the flanges on either side of the section on the replacement part. Cut 5 mm (3/16 in) wide gaps in the corners.

**Important:** The metal of the hinge pillar is of a heavy gage. However, the tabs can be creating using the appropriate tools.

3. Step the tabs inward to allow the service section to fit under the original hinge pillar. Weld the tabs together along the edges.
4. Drill 8-mm (5/16-in) plug weld holes along the sectioning cut on the remaining original part. Locate these holes 13 mm (1/2 in) from the edge and spaced 40 mm (1½ in) apart.

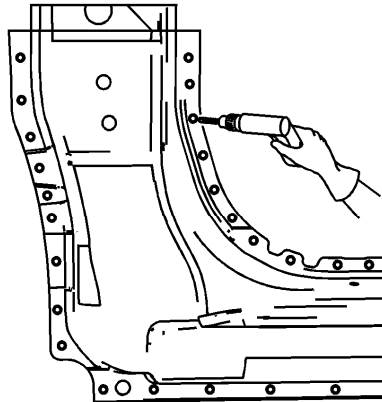

**Important:** In any area damaged beyond recognition, or if structural Weld-Thru adhesive is present, space the plug weld holes 40 mm (1½ in) apart.

5. Drill 8-mm (5/16-in) plug weld holes in the service part as necessary in the locations noted from the original panel and along the sectioning cut.
6. Prepare all mating surfaces as necessary.
7. Apply GM-approved Weld-Thru Coating or equivalent to all mating surfaces. Refer to [Anti-Corrosion Treatment and Repair](#).
8. Position the hinge pillar.

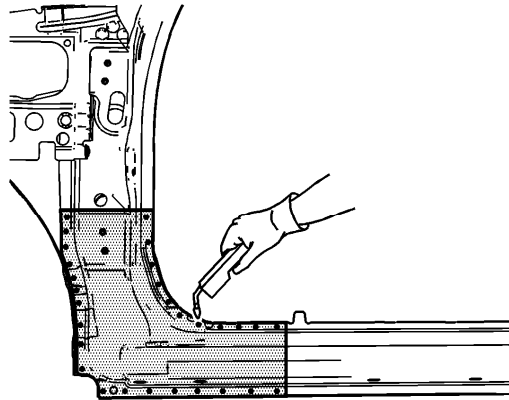

9. Plug weld accordingly.

**Important:** To create a solid weld with minimum heat distortion make 25-mm (1-in) stitch welds along the seam with 25 mm (1 in) gaps between. Then go back and complete the stitch weld.

10. Stitch the weld sectioning joint.
11. Clean and prepare all welded surfaces.
12. Apply the sealers and anti-corrosion materials to the repair area, as necessary. Refer to [Anti-Corrosion Treatment and Repair](#) in Paint/Coatings.
13. Paint and repair the area. Refer to [Basecoat/Clearcoat Paint Systems](#) in General Information.
14. Install all related panels and components.
15. Connect the negative battery cable. Refer to [Battery Negative Cable Disconnection and Connection](#) in Engine Electrical.
16. Enable the SIR system. Refer to [SIR Disabling and Enabling](#) in SIR.