

# Front Wheelhouse Replacement

## Removal Procedure

**Caution:** Refer to [Approved Equipment for Collision Repair Caution](#) in Cautions and Notices.

1. Disable the SIR system. Refer to [SIR Disabling and Enabling](#) in SIR.
2. Disconnect the negative battery cable. Refer to [Battery Negative Cable Disconnection and Connection](#) in Engine Electrical.

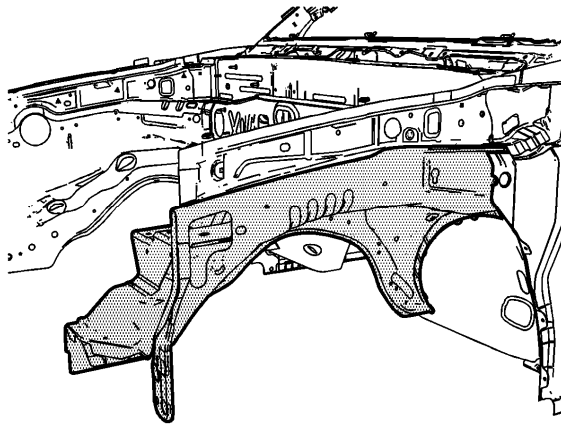

3. Remove all related panels and components.
4. Repair as much of the damage as possible to factory specifications. Refer to [Dimensions - Body](#).
5. Note the location and remove the sealers and anti-corrosion materials from the repair area, as necessary. Refer to [Anti-Corrosion Treatment and Repair](#) in Paint and Coatings.

6. Remove the radiator support. Refer to [Radiator Support Replacement](#) .

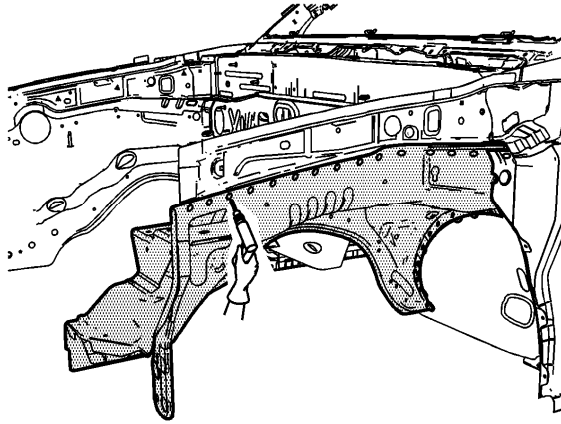

**Important:** Do not damage any inner panels or reinforcements.

7. Locate and drill out all factory welds. Note the number and location of welds for installation of the service part.

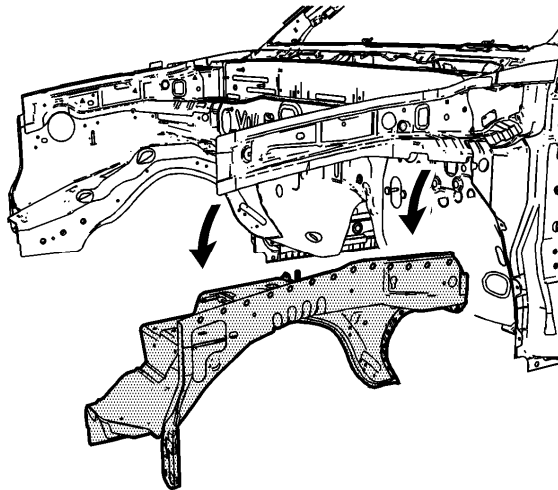

8. Remove the damaged front wheelhouse.

## [Installation Procedure](#)

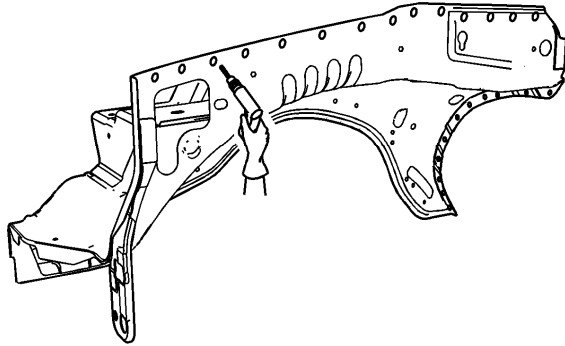

**Important:** If the location of the original plug weld holes can not be determined, or if structural weld-thru adhesive is present, space the plug weld holes every 40 mm (1½ in) apart.

1. Drill 8 mm (5/16 in) plug weld holes in the service part as necessary in the locations noted from the original panel.
2. Prepare all mating surfaces as necessary.
3. Apply GM-approved Weld-Thru Coating or equivalent to all mating surfaces. Refer to [Anti-Corrosion Treatment and Repair](#) .

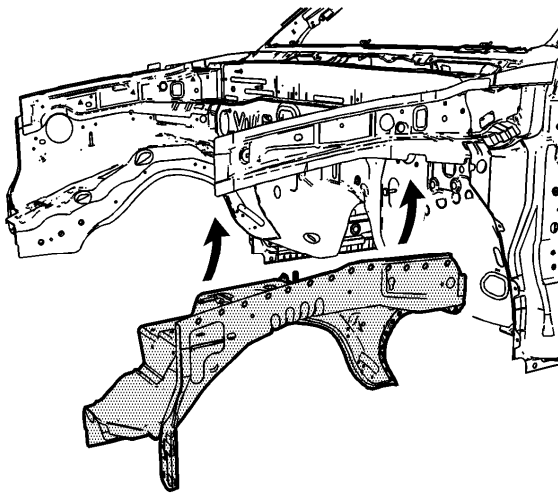

4. Position the front wheelhouse.

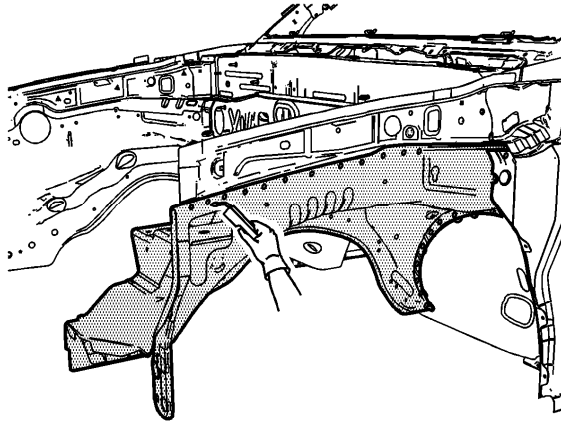

5. Plug weld accordingly.
6. Install the radiator support. Refer to [Radiator Support Replacement](#).

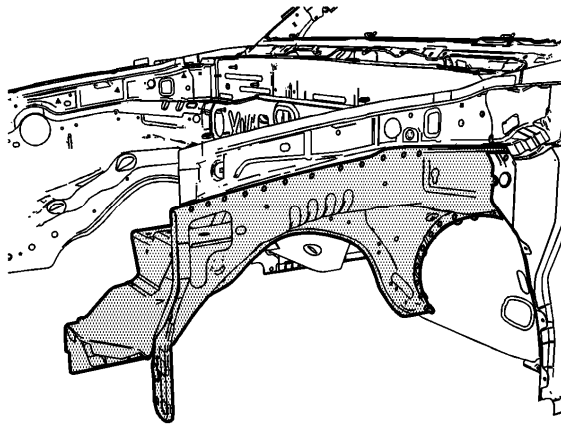

7. Clean and prepare all welded surfaces.
8. Apply the sealers and anti-corrosion materials to the repair area, as necessary. Refer to [Anti-Corrosion Treatment and Repair](#) in Paint and Coatings.
9. Paint and repair the area. Refer to [Basecoat/Clearcoat Paint Systems](#) in Paint and Coatings.
10. Install all related panels and components.
11. Connect the negative battery cable. Refer to [Battery Negative Cable Disconnection and Connection](#) in Engine Electrical.
12. Enable the SIR system. Refer to [SIR Disabling and Enabling](#) in SIR.

