

# Quarter Panel Sectioning

## Removal Procedure

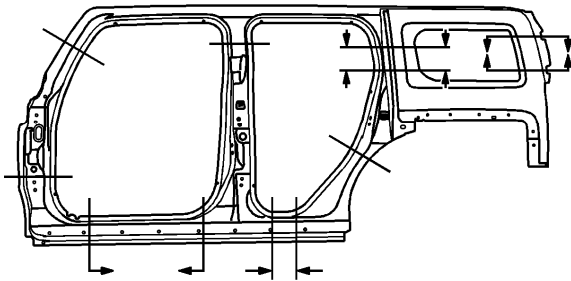

### **Caution**

Refer to [Approved Equipment for Collision Repair Caution](#) in Cautions and Notices.

### **Important**

Section in specified areas only. Sectioning outside of these areas may compromise the structural integrity of the vehicle. The quarter panel can be replaced at factory seams, but requires the roof flange spot welds to be removed along the top of the quarter panel. The sectioning procedures have been developed as a more cost-effective alternative to complete replacement.

### **Important**

When replacing panels that involve servicing of stationary glass, refer to service bulletin 431045 before performing any priming or refinishing.

1. Disable the SIR system. Refer to [SIR Disabling and Enabling Zones](#) in SIR.

2. Disconnect the negative battery cable. Refer to [Battery Negative Cable Disconnect/Connect Procedure](#) in Engine Electrical.
3. Remove all related panels and components.
4. Repair as much of the damage as possible to factory specifications. Refer to [Dimensions - Body](#) .

### **Caution**

Refer to [Foam Sound Deadeners Caution](#) in Cautions and Notices.

5. Note the location and remove the sealers and anti-corrosion materials from the repair area, as necessary. Refer to [Anti-Corrosion Treatment and Repair](#) in Paint and Coatings.

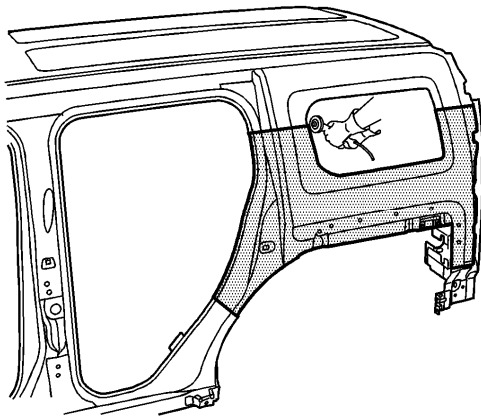

### **Important**

Do not damage any inner panels or reinforcements.

- Cut the panel where sectioning is to be performed.

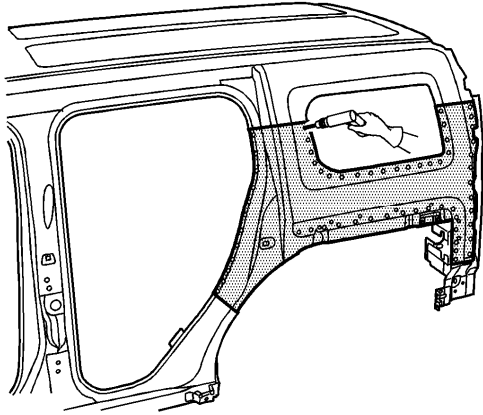

- Locate and drill out all factory welds. Note the number and location of the welds for installations of the service part.

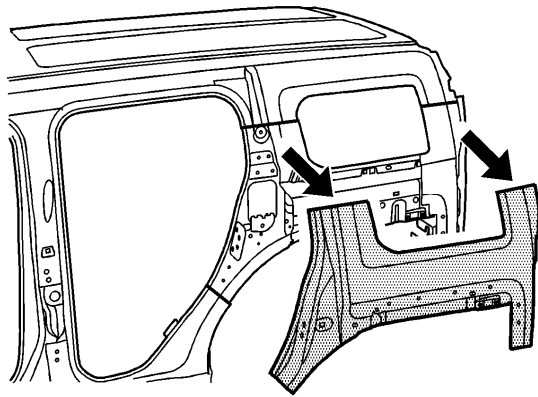

- Remove the damaged quarter panel.

[Installation Procedure](#)

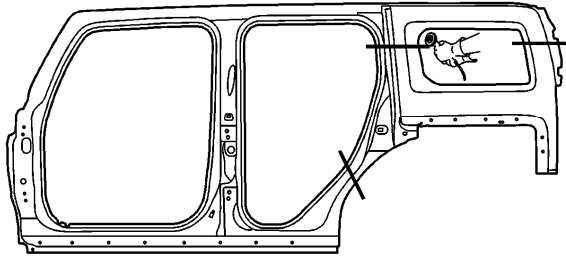

1. Cut the replacement quarter panel section in corresponding locations to fit the original panel. The sectioning joint should be trimmed to allow  $1\frac{1}{2}$  times the metal thickness at the sectioning joint.

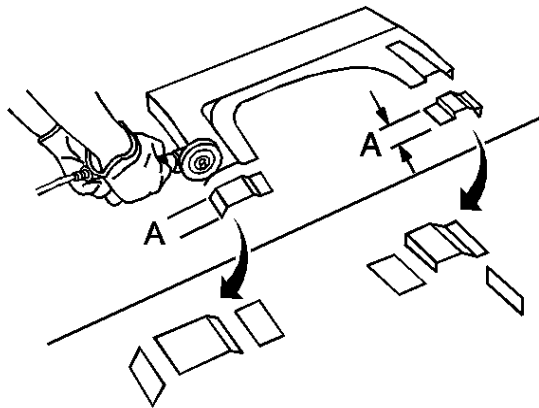

2. Create a 50 mm (2 in) backing plate (A) from the unused portion of the service part. Trim the backing plate as necessary to fit behind the sectioning joint where there is no reinforcement.

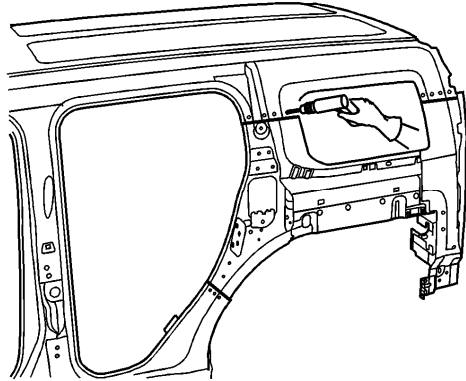

3. Drill 8 mm (5/16 in) plug weld holes along the sectioning cut on the remaining original part. Locate these holes 13 mm (1/2 in) from the edge and spaced 40 mm (1½ in) apart.

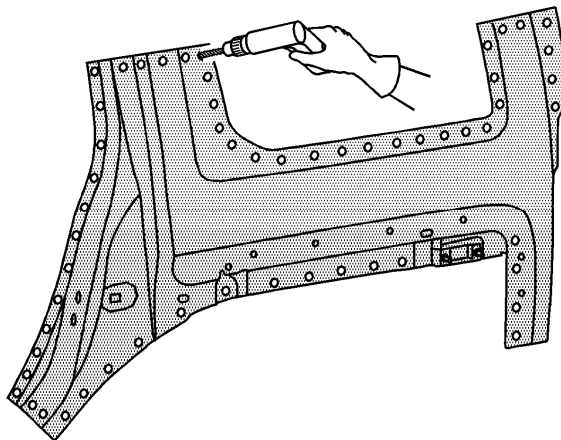

### **Important**

In any area damaged beyond recognition, or if structural weld-thru adhesive is present, space the plug weld holes 40 mm (1½ in) apart.

4. Drill 8 mm (5/16 in) plug weld holes in the service part as necessary in the locations noted from the original panel and along the sectioning cut.

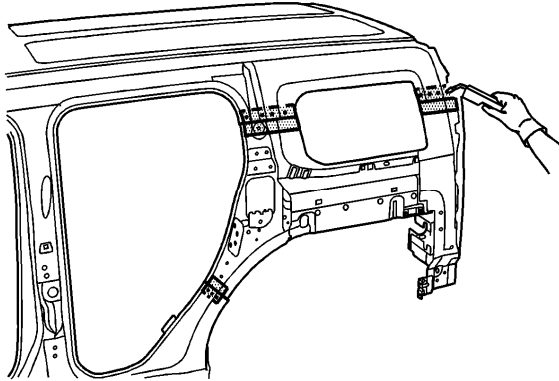

5. Prepare all attachment surfaces as necessary.
6. Apply GM-approved Weld-Thru Coating or equivalent to all mating surfaces. Refer to [Anti-Corrosion Treatment and Repair](#) .
7. Fit the backing plate halfway into the sectioning joint, clamp and plug weld to the vehicle.

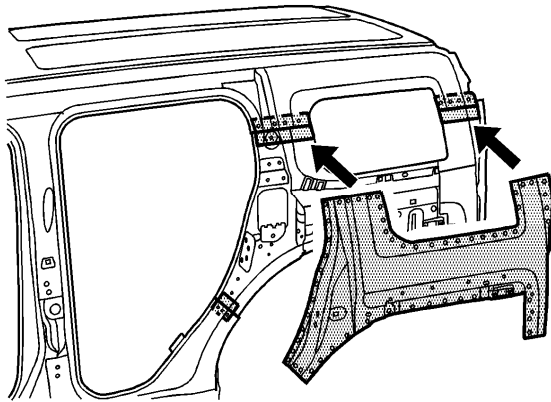

8. Position the quarter panel.

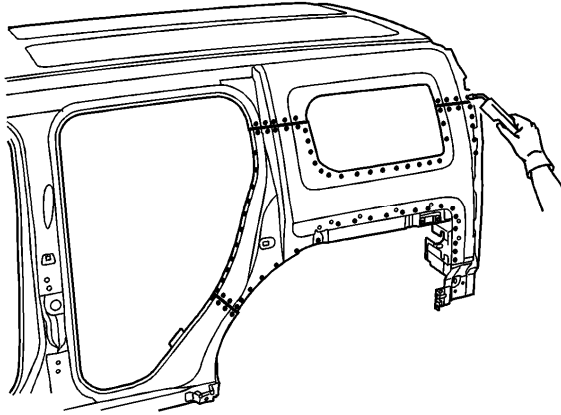

9. Plug weld accordingly.

**Important**

To create a solid weld with minimum heat distortion make 25 mm (1 in) stitch welds along the seam with 25 mm (1 in) gaps between them. Then go back and complete the stitch weld.

10. Stitch the weld sectioning joint.
11. Clean and prepare all welded surfaces.
12. Apply the sealers and anti-corrosion materials to the repair area, as necessary. Refer to [Anti-Corrosion Treatment and Repair](#) in Paint and Coatings.
13. Paint and repair the area. Refer to [Basecoat/Clearcoat Paint Systems](#) in Paint and Coatings.
14. Install all related panels and components.
15. Connect the negative battery cable. Refer to [Battery Negative Cable Disconnect/Connect Procedure](#) in Engine Electrical.
16. Enable the SIR system. Refer to [SIR Disabling and Enabling Zones](#) in SIR.