

Rail Replacement (Upper)

Removal Procedure

1. Remove all related panels and components.
2. Restore as much of the damage as possible to factory specifications.
3. Note the location and remove the following as necessary:
 - Anti-corrosion materials
 - Sound deadeners
 - Sealers

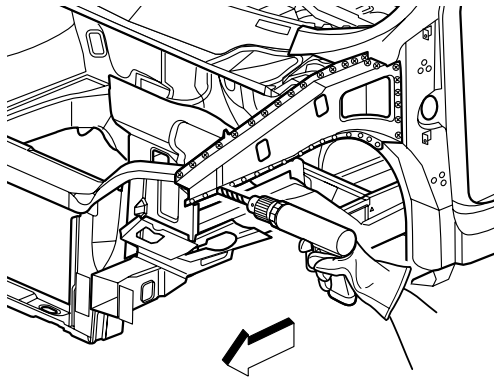
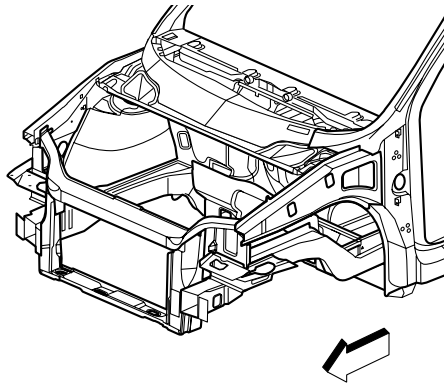

IMPORTANT: Do not damage any inner panels or reinforcements.

4. Locate and drill out all factory welds. Note the number and location of welds for installation of the Front Upper Rail.

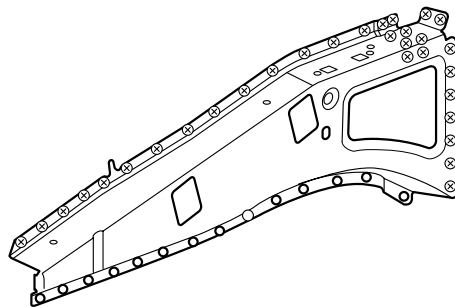

5. Remove the damaged Front Upper Rail.

Rail Replacement (Upper)

Installation Procedure

IMPORTANT: In any area damaged beyond recognition, space plug weld holes every 40 mm (1-1/2 in) apart.

1. Drill 8 mm (5/16 in.) plug weld holes as necessary in locations noted from the original front upper rail.
2. Prepare all attachment surfaces as necessary.
3. Apply weld-thru primer to all bare-metal surfaces.
4. Position the Upper Rail.

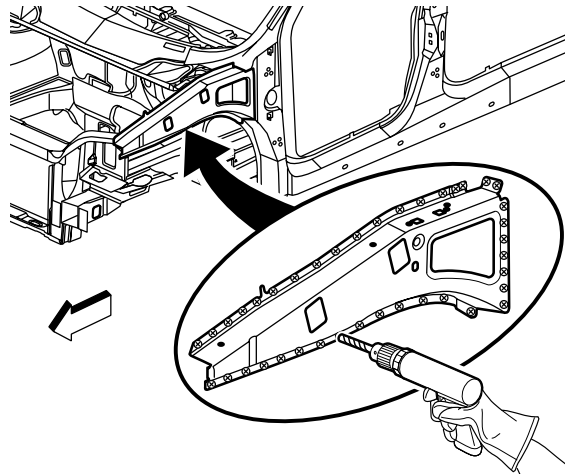

5. Plug weld accordingly.

IMPORTANT: Prior to refinishing, refer to publication GM4901M-D-01 GM Approved Refinish Materials for recommended products. Do not combine paint systems. Refer to paint manufacturer's recommendations.

6. Clean and prepare all welded surfaces.
7. Apply the following as necessary:
 - Anti-corrosion materials
 - Sound deadeners
 - Sealers
8. Refinish as necessary.
9. Install all related panels and components.

