

Rail Sectioning— Rear

Removal Procedure

IMPORTANT: Rear rail sectioning may require replacement of the rear floor panel.

1. Remove all related panels and components.
2. Restore as much of the damage as possible to factory specifications.
3. Note the location and remove the following as necessary:
 - Anti-corrosion materials
 - Sound deadeners
 - Sealers

IMPORTANT: Do not damage any inner panels or reinforcements.

4. Perform the necessary procedures to gain access to the rear rail.
5. Locate and drill out all factory welds. Note the number and location of welds for installation of the rear rail.

6. Mark the cut location by measuring 5 mm (1/4 in.) from the rear edge of the second gauge hole rearward

7. Cut the rear rail section.

8. Remove the damaged rear rail section.

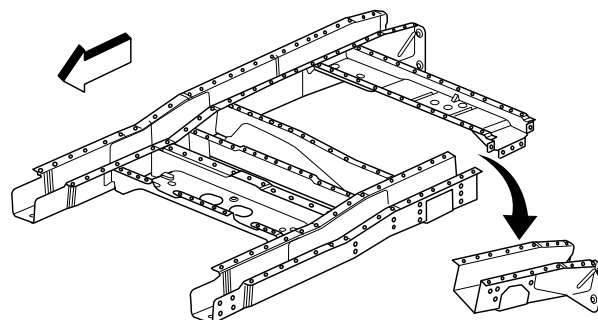
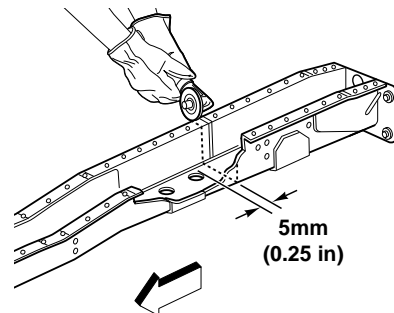
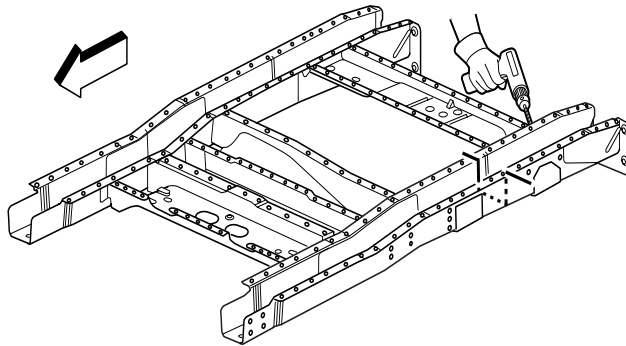
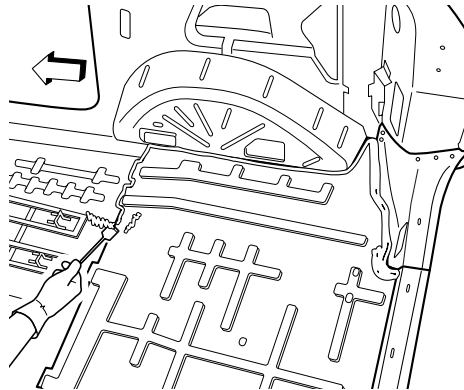

Rail Sectioning—Rear

Installation Procedure

1. Mark the cut location on the service rail by measuring 5 mm (1/4 in.) from the front edge of the second gauge hole forward.

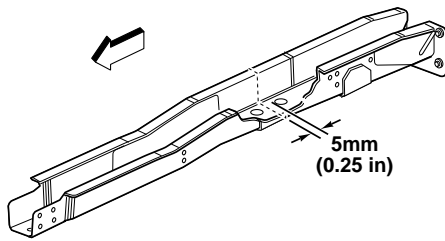

2. Cut the rear rail service part.

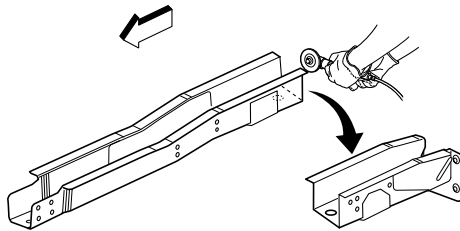

3. Cut and remove 30 mm (1 and 3/16 in.) from the flanges on either side of the service section rail to create 30 mm (1 and 3/16 in.) tabs (1).

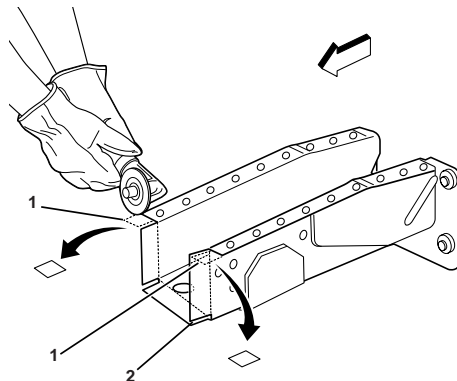

4. Cut 5 mm (1/4 in.) wide gaps in the bottom corners (2).

5. Step the tabs inward (1) to allow the service rail section to fit inside of the original rear rail.

IMPORTANT: The metal of the rear rail is of a heavy gauge. However, the tabs can be created using the appropriate tools.

6. Weld the tabs together along the lower edges (2).

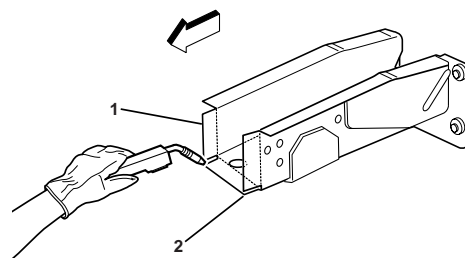

—continued

Rail Sectioning—Rear Installation Procedure con't

IMPORTANT: In any area damaged beyond recognition, space plug weld holes every 40 mm (1-1/2 in.) apart.

7. Drill 8 mm (5/16 in.) plug weld holes along the sectioning cut on the original rail. Locate these holes 13 mm (1/2 in.) from the edge and spaced 40 mm (1/2 in.) apart.
8. Prepare all attachment surfaces as necessary.
9. Turn the weld flange downward for rewelding (2).
10. Apply weld-thru primer to all bare-metal surfaces.

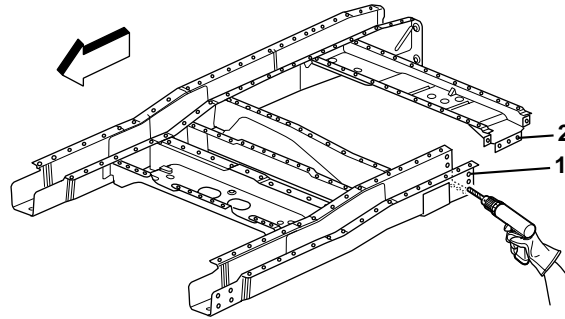

11. Align the service part over the stepped tab using three-dimensional measuring equipment.

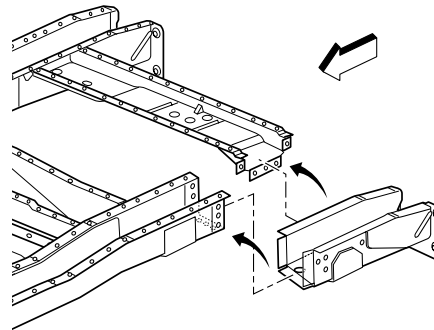

12. Plug weld accordingly.

—continued

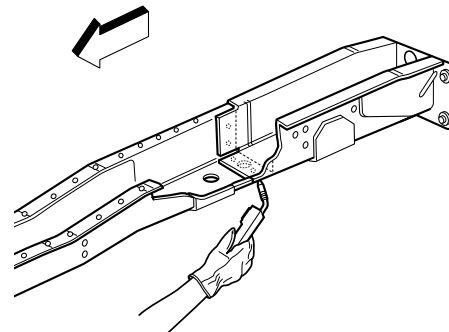

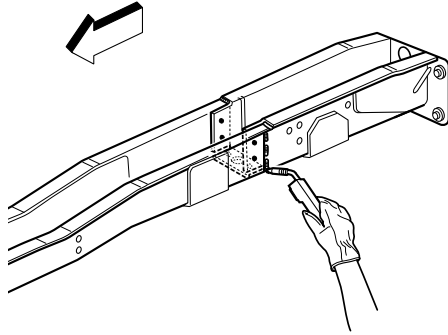

Rail Sectioning—Rear Installation Procedure con't

- To create a solid weld with minimum heat distortion, make 25 mm (1 in.) stitch welds along the seam with 25 mm (1 in.) gaps between them. Then go back and complete the stitch weld.

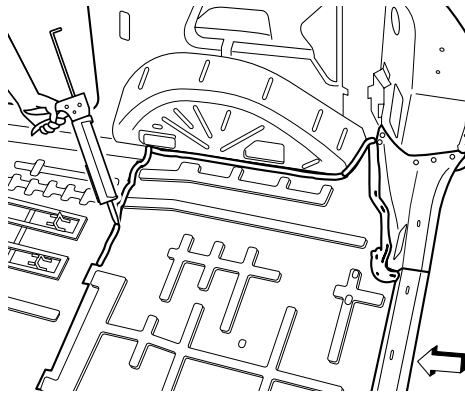

IMPORTANT: Prior to refinishing, refer to publication GM4901M-D-01 GM Approved Refinish Materials for recommended products. Do not combine paint systems. Refer to paint manufacturer's recommendations.

- Clean and prepare all welded surfaces.
- Apply the following as necessary:
 - Anti-corrosion materials
 - Sound deadeners
 - Sealers
- Install all related panels and components.