

Panel Replacement – Rear End

Removal Procedure

1. Remove all related panels and components.
2. Restore as much of the damage as possible to factory specifications.
3. Note the location and remove the following as necessary:
 - Anti-corrosion materials
 - Sound deadeners
 - Sealers

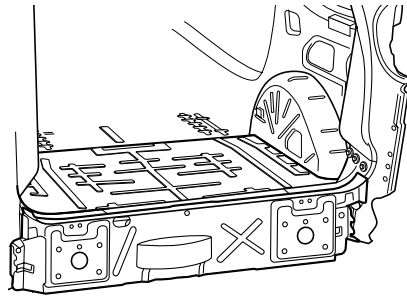

IMPORTANT: Do not damage any inner panels or reinforcements.

4. Locate and drill out all factory welds. Note the number and location of welds for installation of the rear body opening right and left lower reinforcements, gaining access to the rear floor panel.

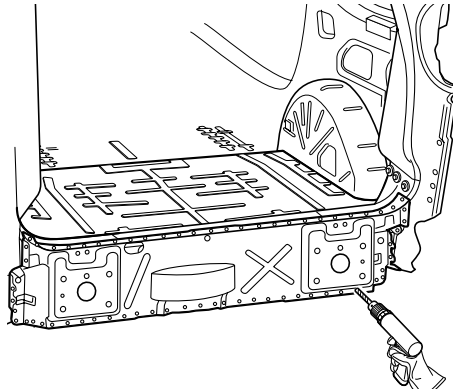

5. Remove the Rear End Panel.

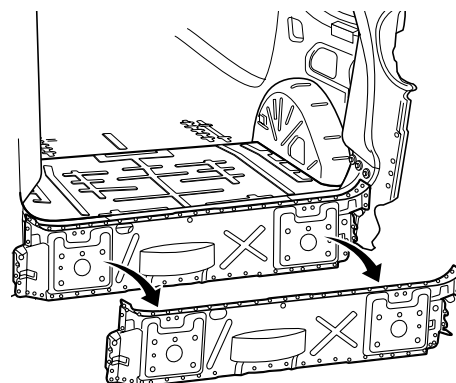

Panel Replacement – Rear End

Installation Procedure

IMPORTANT: In any area damaged beyond recognition, space plug weld holes every 40 mm (1-1/2 in.) apart.

1. Drill 8 mm (5/16 in.) plug weld holes in the service part as necessary in locations noted from the original panel.
2. Prepare all attachment surfaces as necessary.
3. Apply weld-thru primer to all bare-metal surfaces.
4. Position the Rear End Panel.

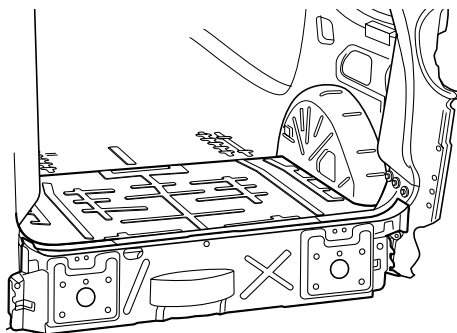
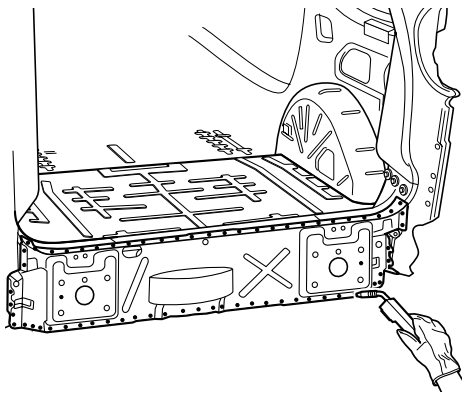
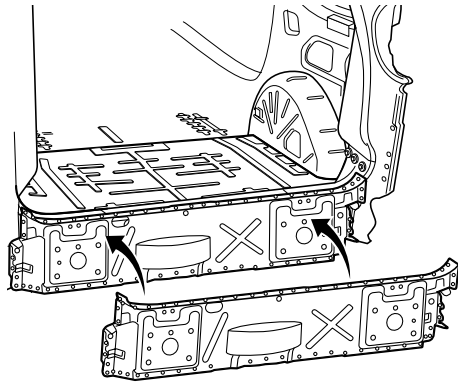
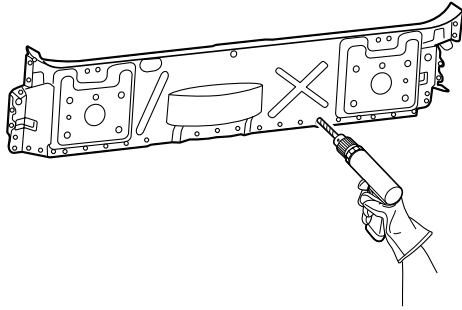

5. Plug weld accordingly.

IMPORTANT: Prior to refinishing, refer to publication GM4901M-D-01 GM Approved Refinish Materials for recommended products. Do not combine paint systems. Refer to paint manufacturer's recommendations.

6. Clean and prepare all welded surfaces.
7. Apply the following as necessary:
 - Anti-corrosion materials
 - Sound deadeners
 - Sealers
8. Refinish as necessary.
9. Install all related panels and components.