

Tie Bar Replacement

Removal Procedure

Caution: Refer to *Approved Equipment for Collision Repair Caution* on page 1-1.

1. Disable the SIR system. Refer to *SIR Disabling and Enabling Zones* on page 1-129.

Caution: Refer to *Battery Disconnect Caution* on page 1-1.

2. Disconnect the negative battery cable.
3. Remove all related panels and components.
4. Repair as much of the damage as possible to factory specifications. Refer to *Dimensions - Body (Sedan)* on page 1-2.
5. Note the location and remove the sealers and anti-corrosion materials from the repair area, as necessary. Refer to *Anti-Corrosion Treatment and Repair*.

Important: Do not damage any inner panels or reinforcements.

6. Locate and drill out all factory welds. Note the number and location of the welds for installation of the tie bar.

7. Remove the damaged tie bar.

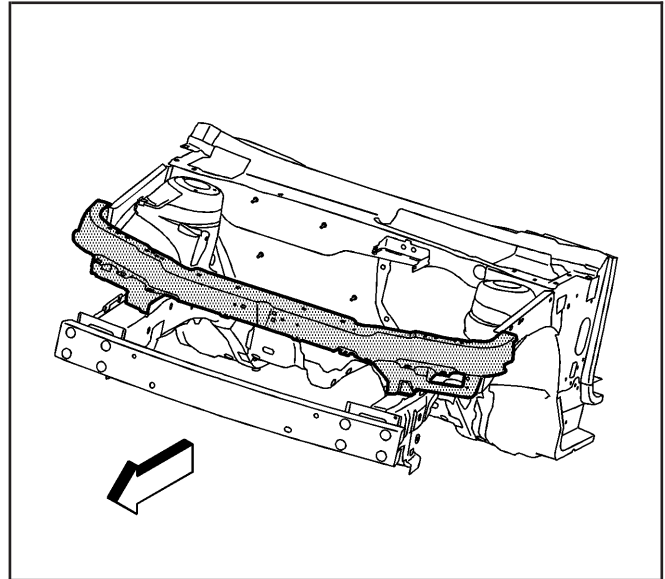

1210281

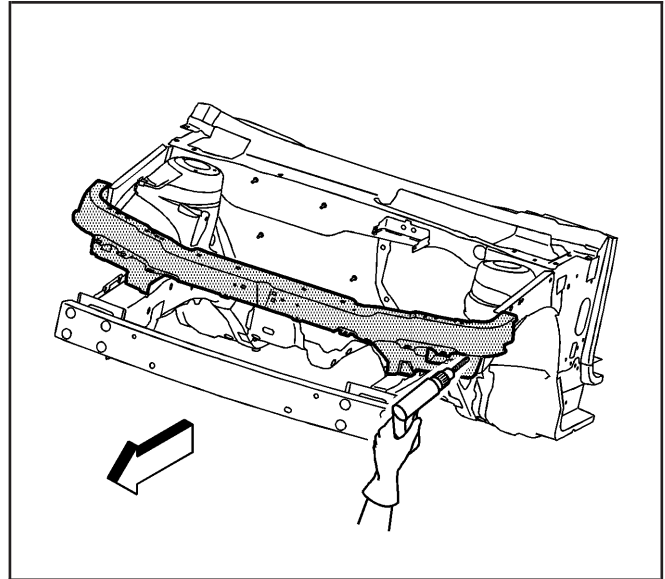

1210289

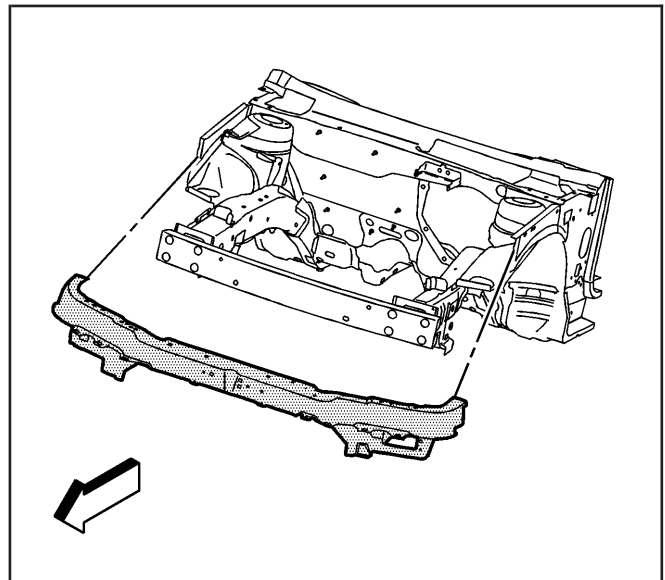

1210296

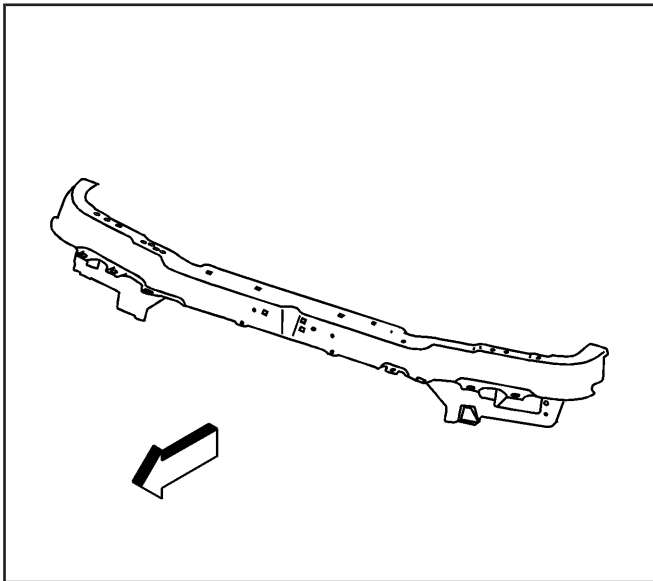

1210300

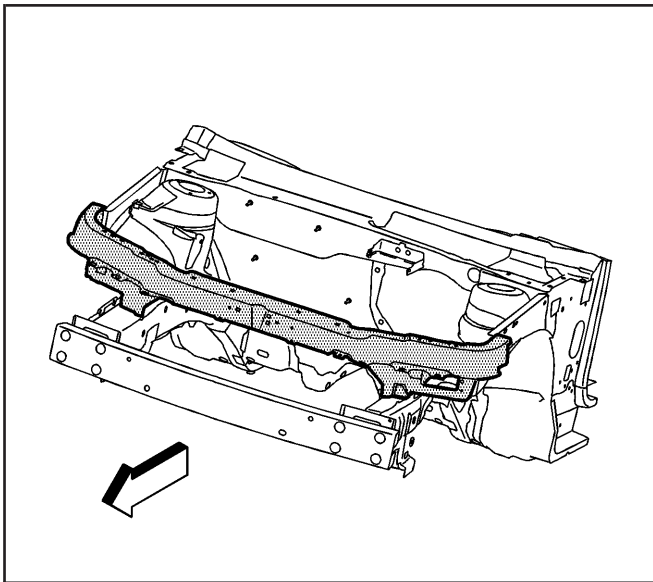

1210281

Installation Procedure

Important: If the location of the original plug weld holes can not be determined, space the plug weld holes every 40 mm (1 1/2 in) apart.

1. Drill 8 mm (5/16 in) plug weld holes in the service part as necessary in the locations noted from the original panel.
2. Prepare all mating surfaces as necessary.
3. Apply 3M Weld-Thru Coating P/N 05916 or equivalent to all mating surfaces.

4. Position the tie bar to the vehicle using 3-dimensional measuring equipment. Clamp the tie bar into place.
5. Plug weld accordingly.
6. Clean and prepare all welded surfaces.
7. Apply the sealers and anti-corrosion materials to the repair area, as necessary. Refer to *Anti-Corrosion Treatment and Repair*.
8. Paint the repair area. Refer to *Basecoat/Clearcoat Paint Systems*.
9. Install all related panels and components.

Caution: Refer to *Battery Disconnect Caution on page 1-1*.

10. Connect the negative battery cable.
11. Enable the SIR system. Refer to *SIR Disabling and Enabling Zones on page 1-129*.