

Rail Replacement Front Compartment - Front Half

Removal Procedure

Caution: Refer to *Approved Equipment for Collision Repair Caution* on page 1-1.

Important: The service part is developed from a complete assembly and will require the spot weld removal at the rail mid joint. The lower rail service part comes as a complete front rail assembly, including all the brackets and the reinforcements.

Important: Loosen and protect the fuel and brake lines during rail replacement.

1. Support the engine and the transmission with suitable equipment.
2. Remove the fasteners to the engine and the transmission.
3. Remove all the other related panels and components as necessary, including the suspension and the crossmember.
4. Visually inspect the damaged area. Repair as much of the damage as possible to factory specifications. Refer to *Dimensions - Body (Sedan)* on page 1-2.
5. Remove the sealers and anti-corrosion materials from the repair area, as necessary. Refer to *Anti-Corrosion Treatment and Repair*.
6. Locate the area where the front compartment will be separated from the rail.

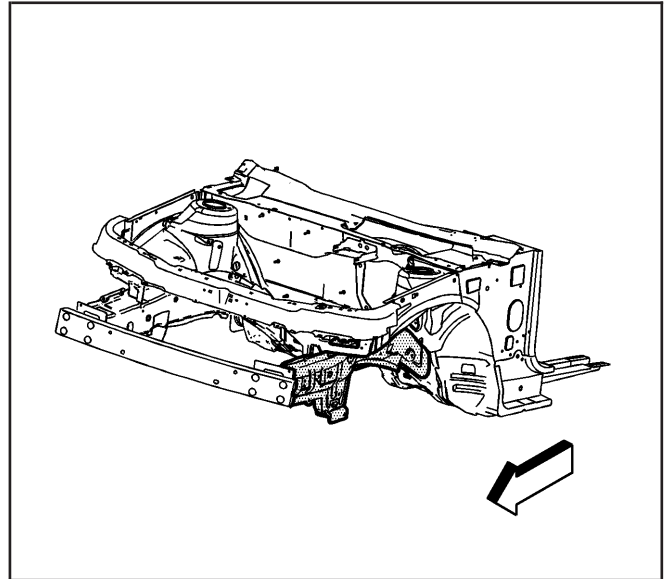

1212777

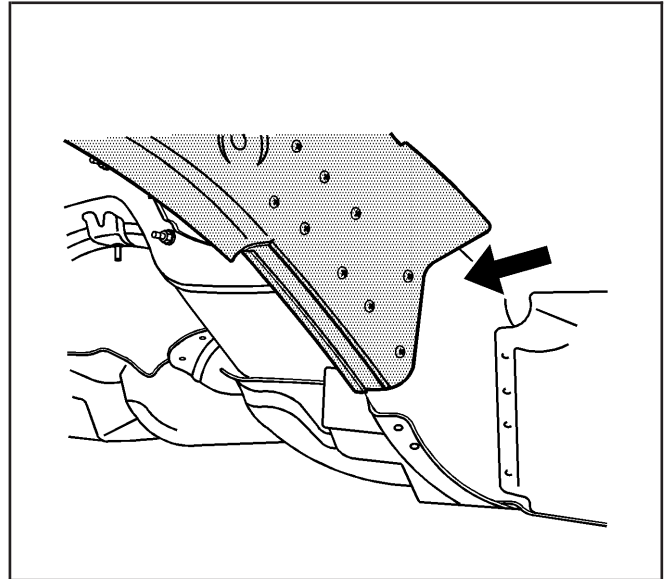

872672

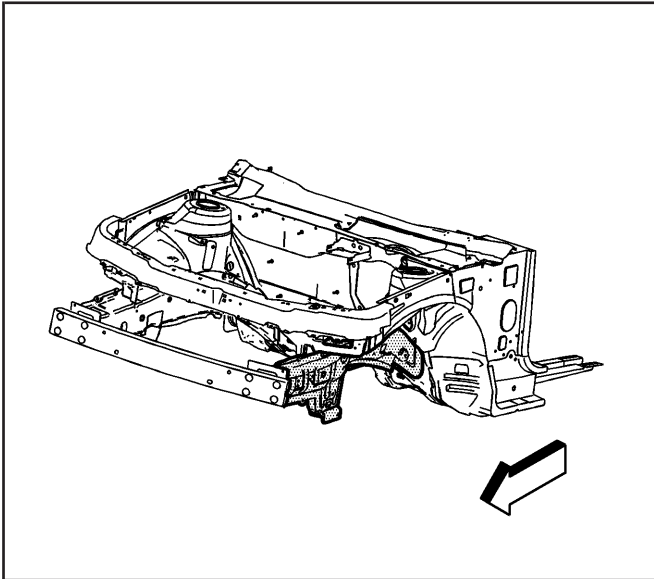

1212777

7. Locate and drill the factory welds along the flanges of the rail, only up to and including the rail mid joint just forward of the dash panel.
8. Drill out the factory welds.

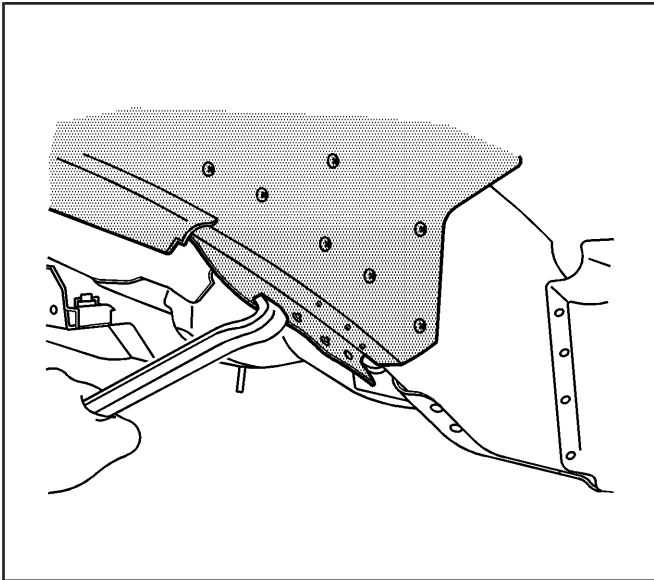

867551

9. Pry open the outer layer of the rail at the front rail mid joint to allow the front portion of the rail to be removed from the vehicle.

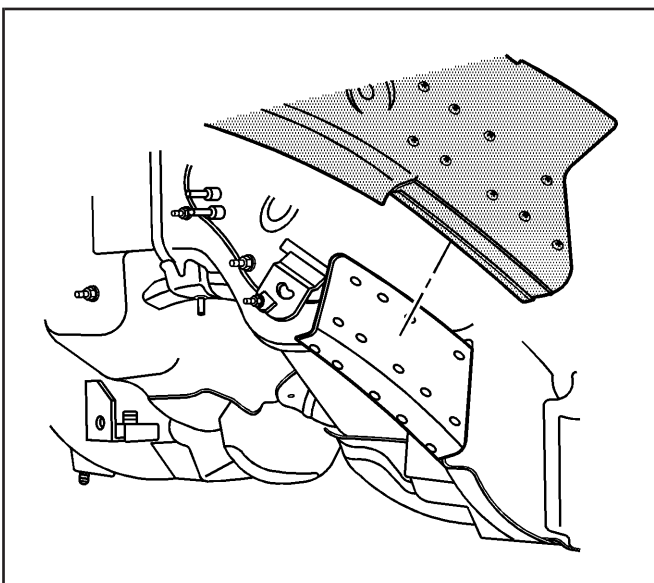

867552

10. Remove the damaged front lower rail.

11. Drill out the factory welds at the service rail assembly mid joint.
12. Remove the forward portion of the front rail assembly at the mid joint.

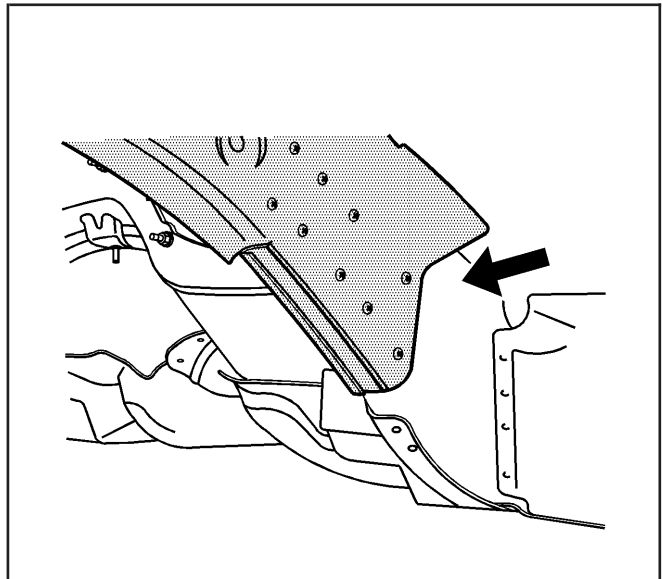

872672

13. Prepare the mating surfaces as necessary.
14. Apply 3M Weld-Thru Coating P/N 05916, or equivalent, to all mating surfaces.

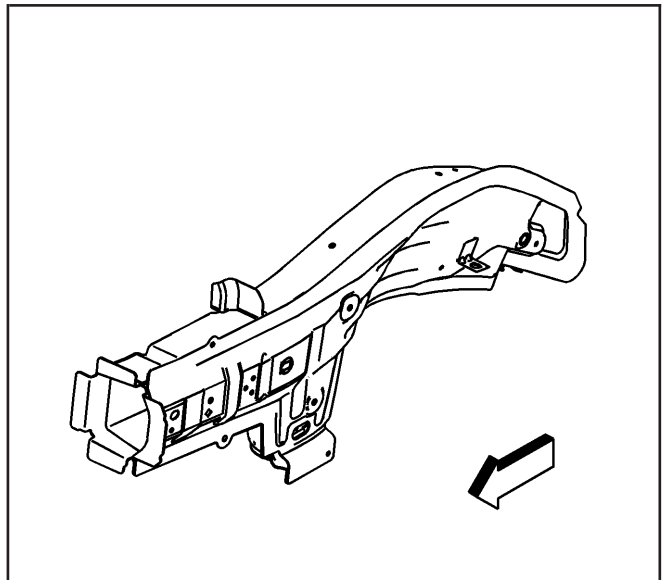

1212781

Installation Procedure

Important: If the location of the original plug weld holes can not be determined, space the plug weld holes every 40 mm (1½ in) apart.

1. Drill 8 mm (5/16 in) plug weld holes in the service part as necessary in the locations noted from the original panel.
2. Prepare all mating surfaces as necessary.
3. Apply 3M Weld-Thru Coating P/N 05916, or equivalent, to all mating surfaces.

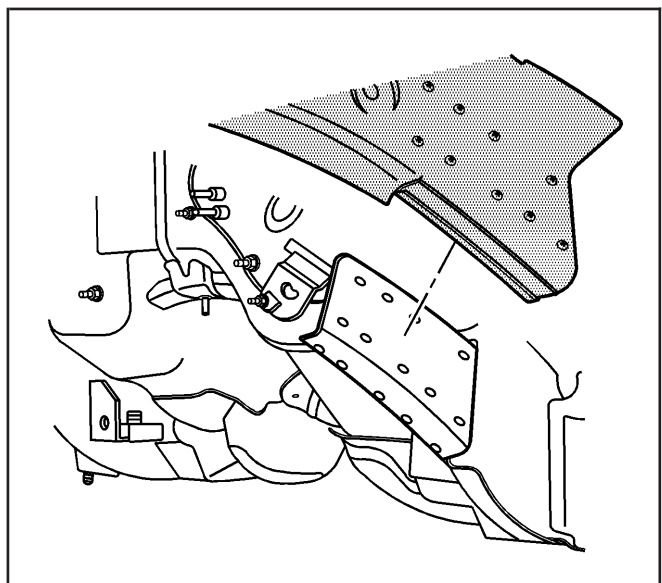

867552

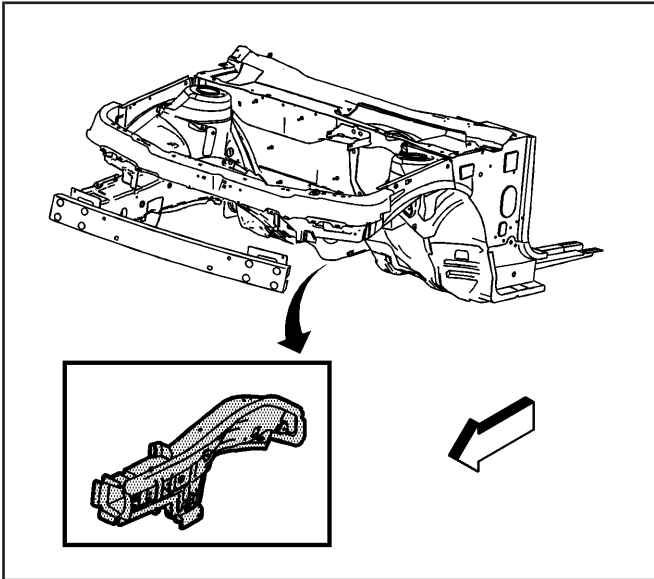

1212785

4. Position the rail to the vehicle.

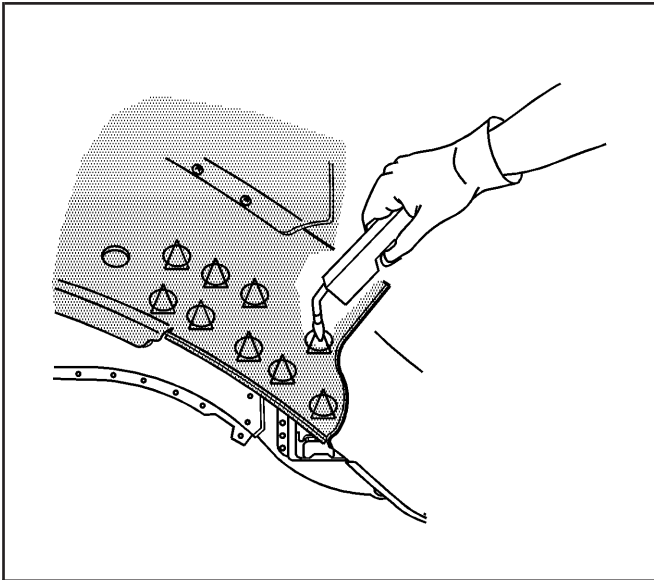

867521

5. Plug weld accordingly.
6. Clean and prepare all of the welded surfaces.
7. Install all related panels and components.
8. Apply sealers and anti-corrosion materials to the repair area, as necessary. Refer to *Anti-Corrosion Treatment and Repair*.
9. Install the suspension crossmember. Refer to *Frame Replacement (W/LX9)*.