

1213012

Rail Replacement Front Side Underbody - Outer

Removal Procedure

Caution: Refer to *Approved Equipment for Collision Repair Caution* on page 1-1.

1. Disable the SIR system. Refer to *SIR Disabling and Enabling Zones* on page 1-129.

Caution: Refer to *Battery Disconnect Caution* on page 1-1.

2. Disconnect the negative battery cable.
3. Remove all related panels and components.
4. Repair as much of the damage as possible. Refer to *Dimensions - Body (Sedan)* on page 1-2.
5. Remove the sealers and anti-corrosion materials from the repair area, as necessary. Refer to *Anti-Corrosion Treatment and Repair*.

Important: Note the number and location of the factory welds for installation of the outer rail.

6. Locate and drill out all the necessary factory welds.
7. Remove the outer rail from the vehicle.

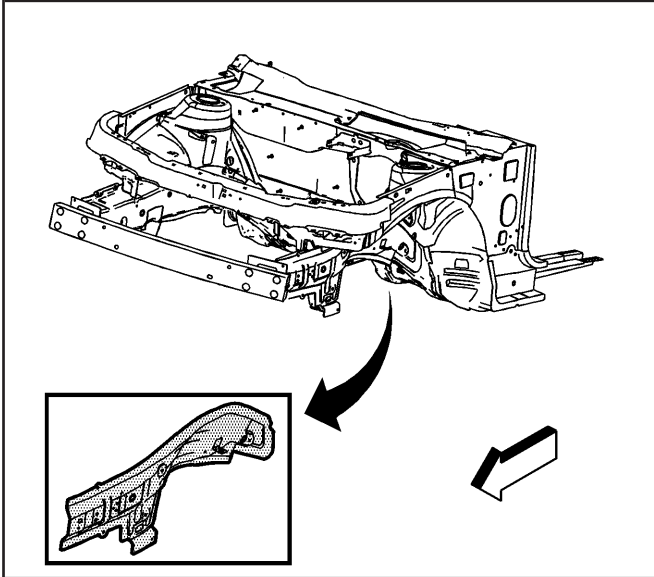

1213014

Installation Procedure

Important: If the location of the original plug weld holes can not be determined, space the plug weld holes every 40 mm (1½ in) apart.

1. Drill 8 mm (5/16 in) plug weld holes in the service part as necessary in the locations noted from the original panel.
2. Prepare all mating surfaces as necessary.
3. Apply 3M Weld-Thru Coating P/N 05916 or equivalent to all mating surfaces.

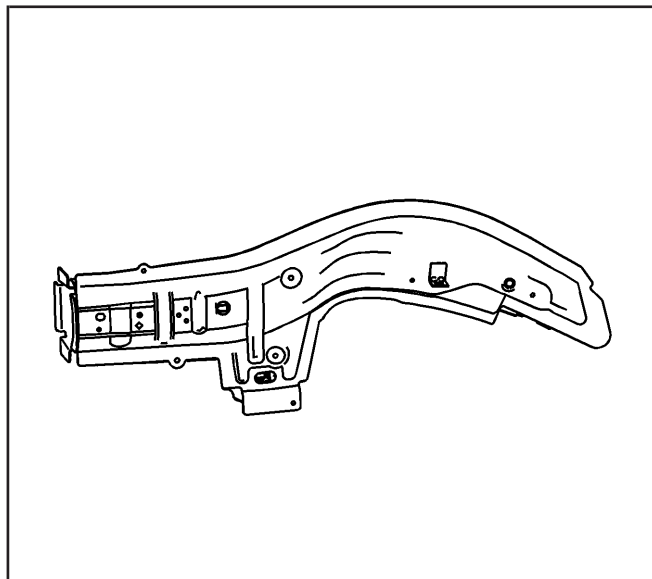

1213015

4. Position the outer rail to the vehicle using 3-dimensional measuring equipment. Clamp the outer rail in place.

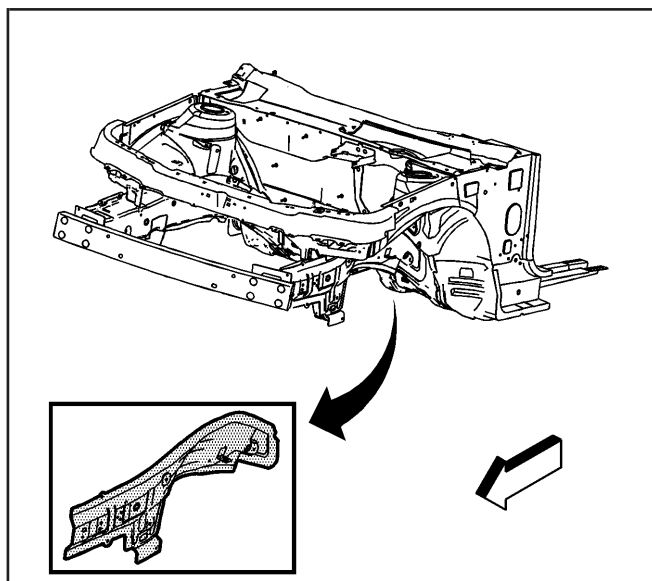

1213014

5. Plug weld accordingly.
6. Clean and prepare all of the welded surfaces.
7. Install all of the related panels and components.
8. Apply the sealers and anti-corrosion materials to the repair area, as necessary. Refer to *Anti-Corrosion Treatment and Repair*.
9. Paint the repaired area. Refer to *Basecoat/Clearcoat Paint Systems*.

Caution: Refer to **Battery Disconnect Caution** on page 1-1.

10. Connect the negative battery cable.
11. Enable the SIR system. Refer to *SIR Disabling and Enabling Zones* on page 1-129.

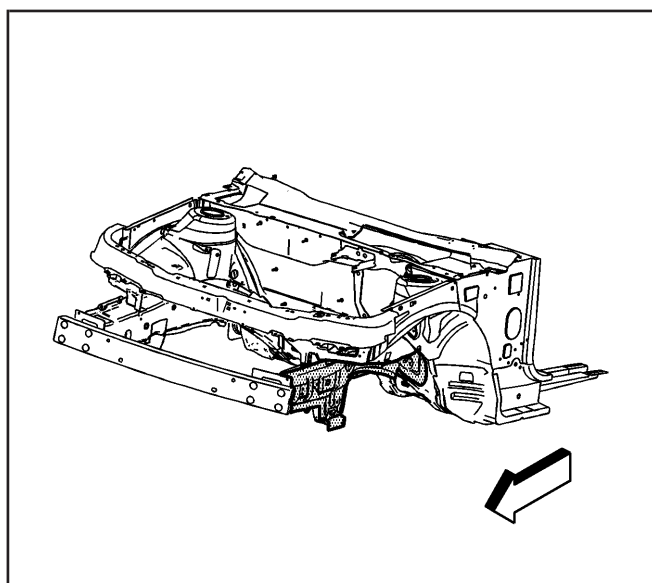

1213012