

Hinge Pillar Sectioning - Front Inner

Removal Procedure

Caution: Refer to *Approved Equipment for Collision Repair Caution on page 1-1*.

The full body side inner panel comes as a one-piece assembly and can be replaced at the factory seams after removal of the outer panels, the roof panel and the front and rear window, any of these sectioning procedures can be performed separately or in any combination, depending on the extent of the damage to the vehicle.

Caution: Sectioning should be performed only in the recommended areas. Failure to do so may compromise the structural integrity of the vehicle and cause personal injury if the vehicle is in a collision.

1. Disable the SIR system. Refer to *SIR Disabling and Enabling Zones on page 1-129*.

Caution: Refer to *Battery Disconnect Caution on page 1-1*.

2. Disconnect the negative battery cable.
3. Remove all related panels and components.
4. Remove the sealers and anti-corrosion materials from the repair area, as necessary. Refer to *Anti-Corrosion Treatment and Repair*.
5. Repair as much of the damage as possible.

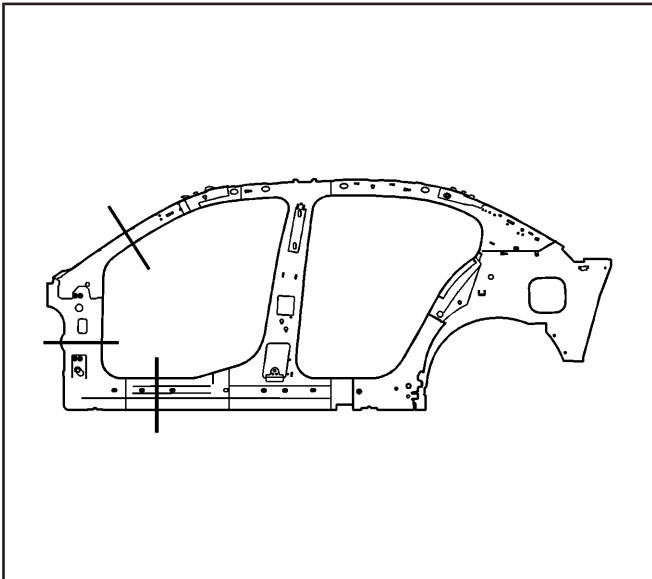

1285105

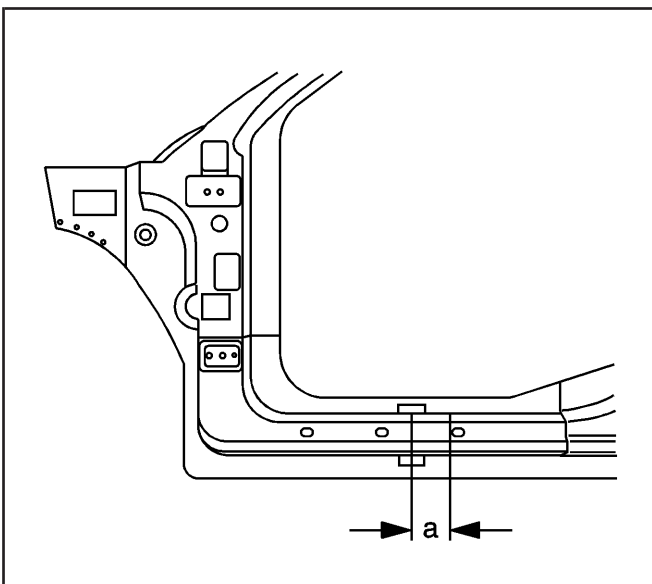

1285108

6. On the inner rocker panel, measure 50 mm (2 in) (a) forward from the front edge of the third rearward hole. This is the cut line.

Important: Do not damage any inner reinforcements or panels.

- Cut the panel where sectioning is to be performed.
- Measure down 80 mm (3.25 in) (a) from the door wiring conduit hole lower edge. This is the cut line.

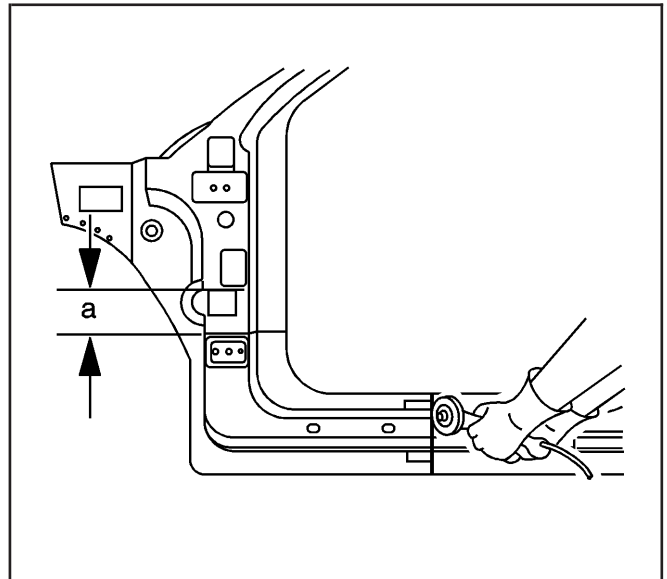

1285110

Important: Note the number and location of the factory welds for installation of the hinge pillar.

- Locate and drill out all factory welds. Note the number and location of the welds for installation of the service part.

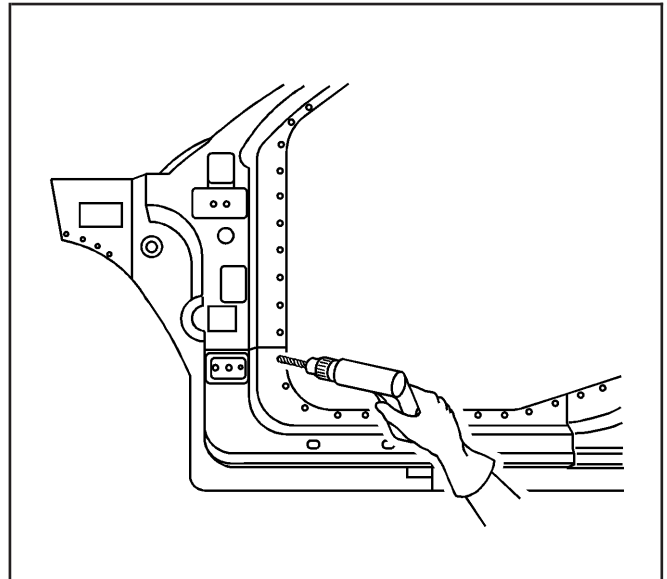

1285113

- Remove the damaged inner hinge pillar.

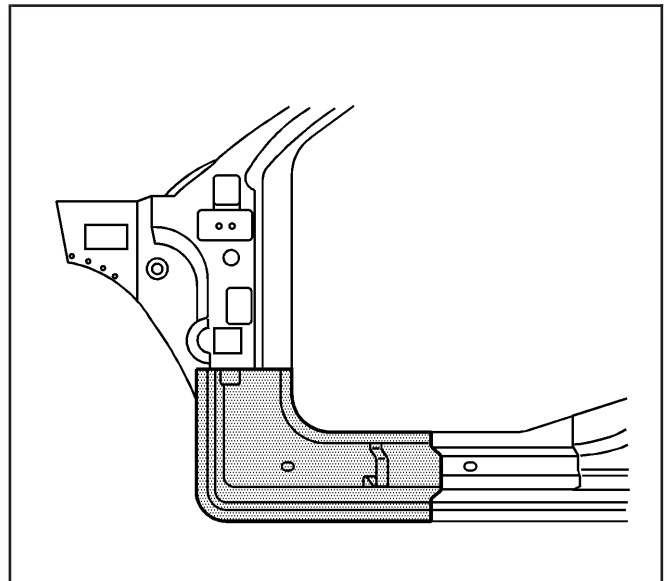

1285115

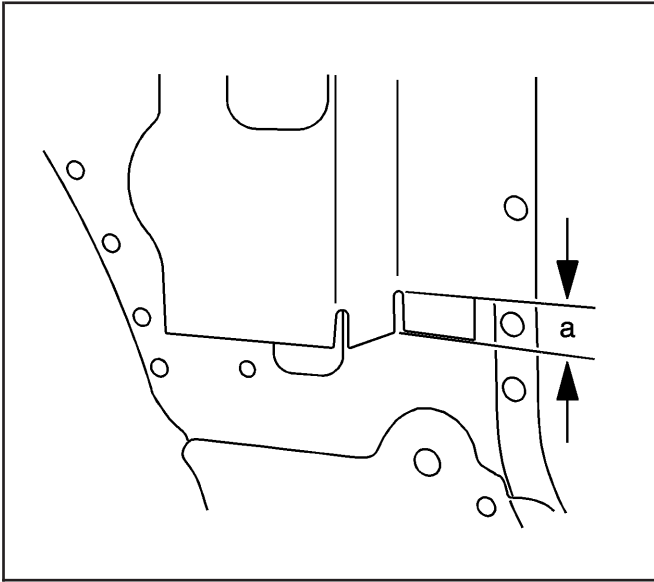

1285117

Installation Procedure

1. On the hinge pillar, after cutting, notch out the corners (a) 20 mm (0.75 in) to accept the service part fit.

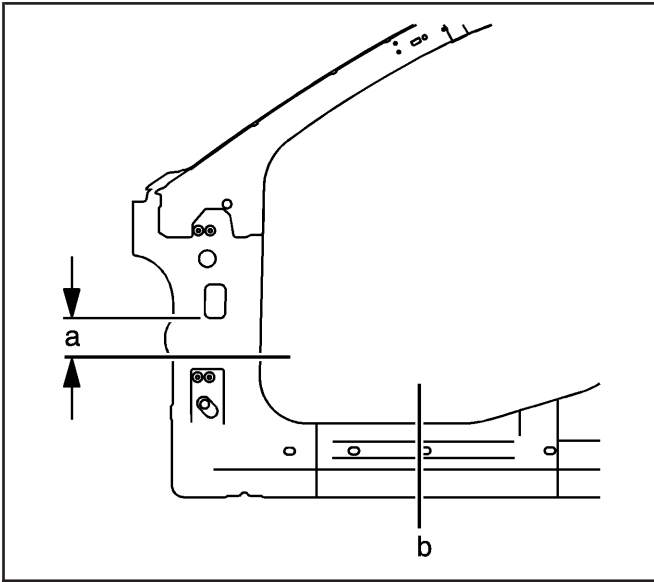

1285118

2. Measure 50 mm (2 in) (a) below the door wiring conduit hole. Cut the replacement service part horizontally.
3. Cut the rocker area vertically at the front edge of the rearward hole (b).

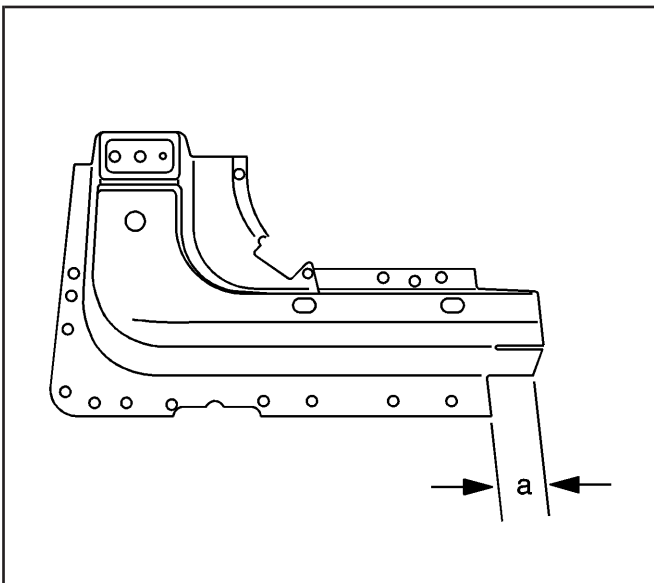

1285121

4. On the service part, notch the corners back 50 mm (2 in) (a) to allow for a full under-lap.

5. Note the number and the location of the factory welds for installation of the service part.
6. Overlap the hinge pillar area. Underlap the rocker area.

Important: If the location of the original plug weld holes can not be determined, or if structural weld-thru adhesive is present, space the plug weld holes every 40 mm (1½ in).

7. Drill 8 mm (5/16 in) plug weld holes in the service part as necessary as noted from the original panel.
8. Prepare all mating surfaces as necessary.
9. Apply 3M Weld-Thru Coating P/N 05913 or equivalent to all mating surfaces.
10. Align service part using 3 dimensional measuring equipment. Clamp in place.

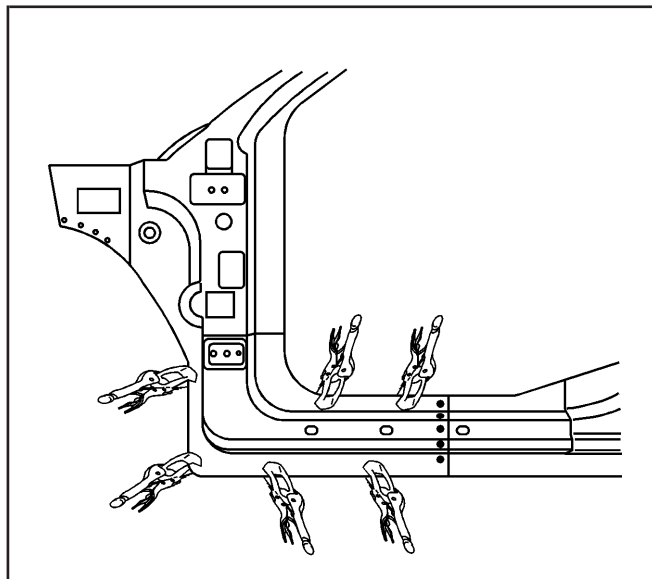

1285125

11. Add plug weld holes 1/2 in from the seam weld.
12. Weld and grind the seam.
13. Plug weld accordingly.
14. Refinish and paint the repaired area. Refer to *Basecoat/Clearcoat Paint Systems*.
15. Install all of the related panels and components.

Caution: Refer to Battery Disconnect Caution on page 1-1.

16. Connect the negative battery cable.
17. Enable the SIR system. Refer to *SIR Disabling and Enabling Zones on page 1-129*.

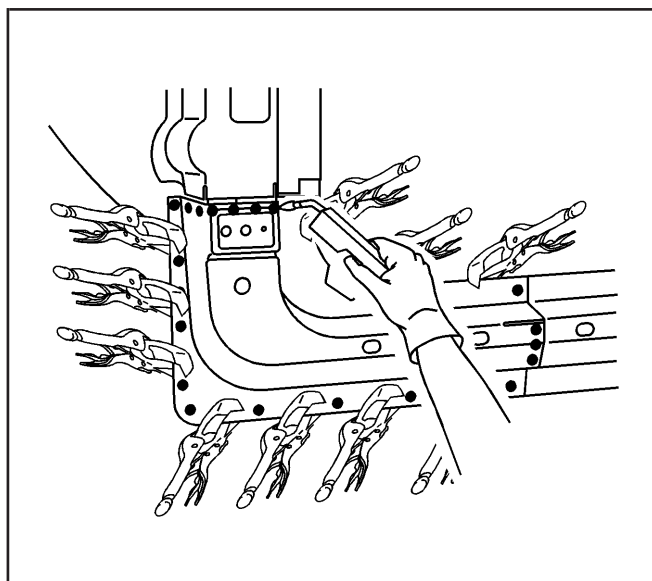

1285126