

## Roof Panel Replacement - Outer

### Removal Procedure

The roof panel is attached to the steel roof structure with beads of adhesive on the sides. The roof panel is attached to the windshield, rear window, and side flanges with spot welds. Replacement of the roof panel can be performed using conventional procedures. The windshield and the rear window must be removed. Refer to *Windshield Replacement* or to *Rear Window Replacement*.

**Caution:** Refer to *Approved Equipment for Collision Repair Caution on page 1-1*.

1. Disable the SIR system. Refer to *SIR Disabling and Enabling Zones on page 1-129*.

**Caution:** Refer to *Battery Disconnect Caution on page 1-1*.

2. Disconnect the negative battery cable.
3. Take note of the gap sizes along the perimeter of the roof panel to the headers, the glass, and the doors.
4. Remove all related panels and components.
5. Repair as much of the damaged area as possible. Refer to *Dimensions - Body (Sedan) on page 1-2*.

**Important:** Do not damage any inner panels or reinforcements.

6. Note the location and remove the sealers and anti-corrosion materials from the repair area, as necessary. Refer to *Anti-Corrosion Treatment and Repair*.
7. Locate and mark all factory welds.
8. Drill out all factory welds. Note the number and locations of the welds for installation of the service assembly.
9. Cut the adhesive with an appropriate tool.

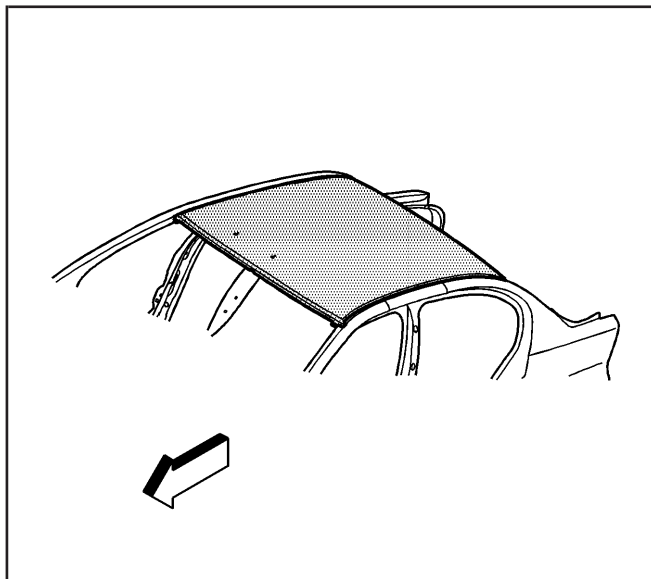

1215277

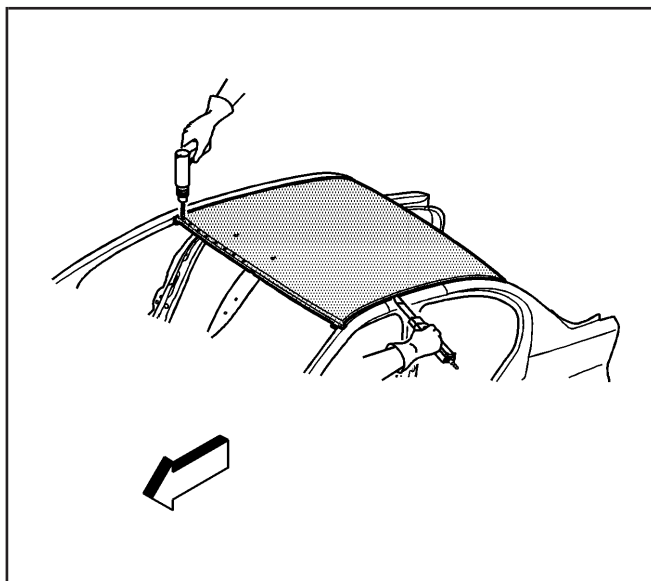

1215444

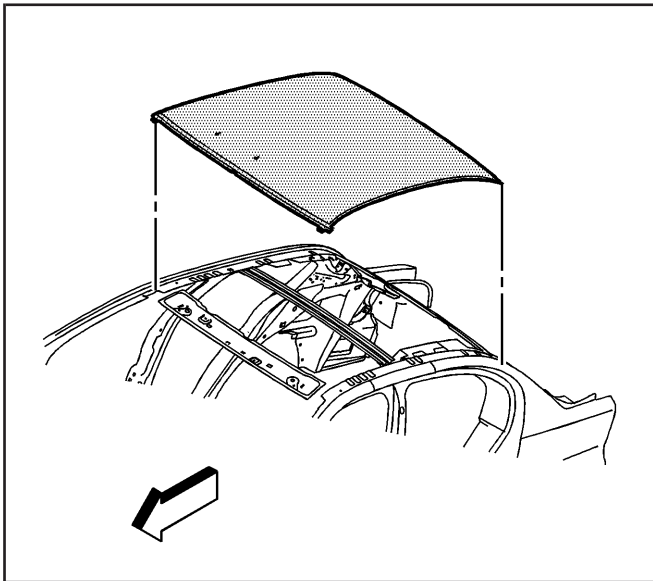

1215290

10. Remove the damaged roof panel.

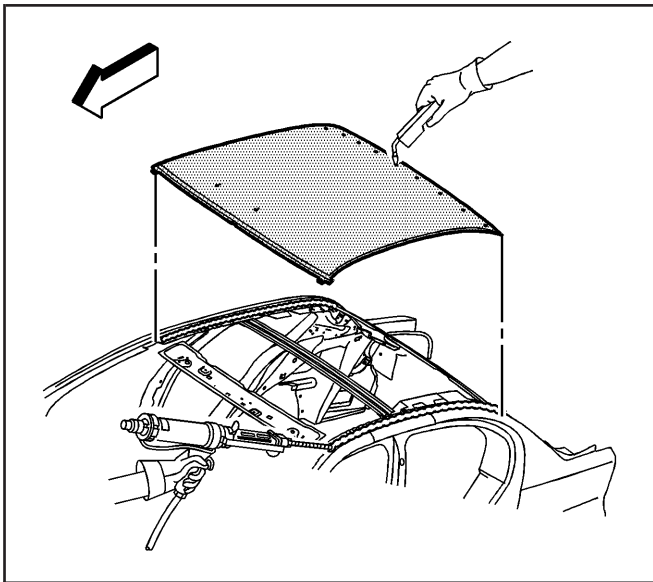

1215449

### Installation Procedure

1. Clean and prepare the mating surfaces for welding.
2. Drill 8 mm (5/16 in) holes for plug welding along the windshield and along the windshield and rear window edges of the service panel as noted from the original panel. Drill the holes for plug welding along the front and rear flanges every 40 mm (1 1/2 in).
3. Prepare all mating surfaces as necessary.
4. Apply 3M<sup>®</sup> Weld-Thru coating P/N 05916 or equivalent to the mating surfaces.
5. Install the panel using one-part windshield urethane kit GM P/N 12346392 on both side rails.

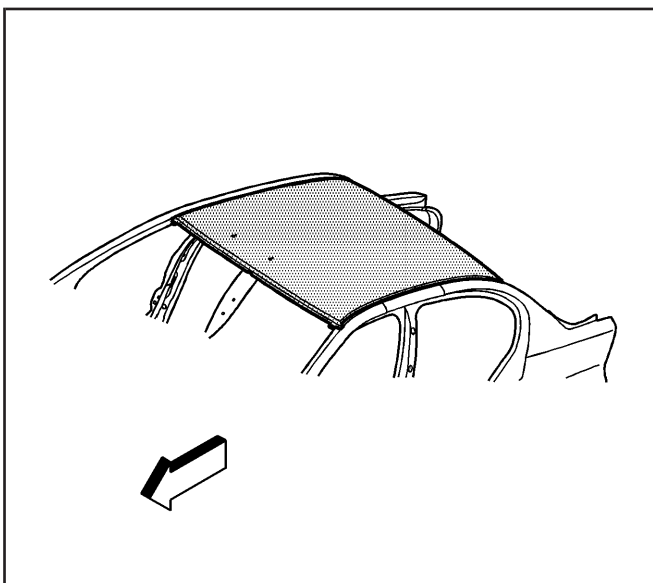

1215277

6. Position the roof panel on the vehicle.
  7. Verify the fit of the panel.
  8. Clamp the panel into place.
  9. Plug weld accordingly.
  10. Apply the sealers and anti-corrosion materials to the repair area, as necessary. Refer to *Anti-Corrosion Treatment and Repair*.
  11. Paint the repair area. Refer to *Basecoat/Clearcoat Paint Systems*.
  12. Install all related panels and components.
- Caution:** Refer to **Battery Disconnect Caution on page 1-1**.
13. Connect the negative battery cable.
  14. Enable the SIR system. Refer to *SIR Disabling and Enabling Zones on page 1-129*.