

Pillar Lock Front Door Reinforcement Sectioning - Outer

Removal Procedure

Caution: Refer to *Approved Equipment for Collision Repair Caution* on page 1-1.

Caution: Sectioning should be performed only in the recommended areas. Failure to do so may compromise the structural integrity of the vehicle and cause personal injury if the vehicle is in a collision.

1. Disable the SIR system. Refer to *SIR Disabling and Enabling Zones* on page 1-129.

Caution: Refer to *Battery Disconnect Caution* on page 1-1.

2. Disconnect the negative battery cable.
3. Remove all related panels and components.
4. Repair as much of the damaged area as possible. Refer to *Dimensions - Body (Sedan)* on page 1-2.
5. Remove the sealers and anti-corrosion materials from the repair area, as necessary. Refer to *Anti-Corrosion Treatment and Repair*.
6. On the center pillar reinforcement, measure down from the top edge of the upper side frame (a) 190 mm (7.5 in). Scribe a line.
7. Cut the panel at the mark made previously. At the same time, completely cut through the outer panel and the inner reinforcements.
8. Locate and drill out all factory welds. Note the number and location of the welds for installation of the service part.

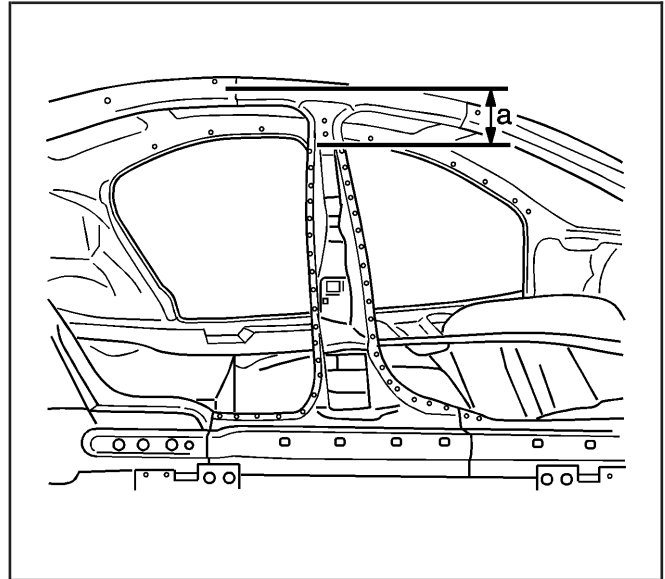

1471540

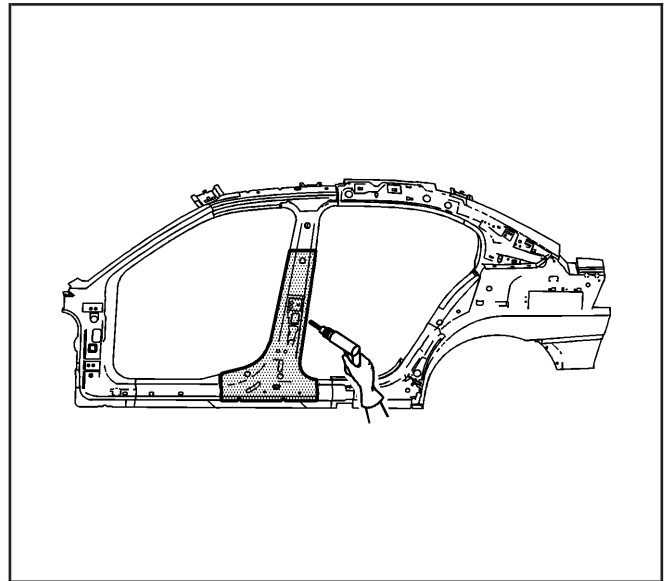

1219541

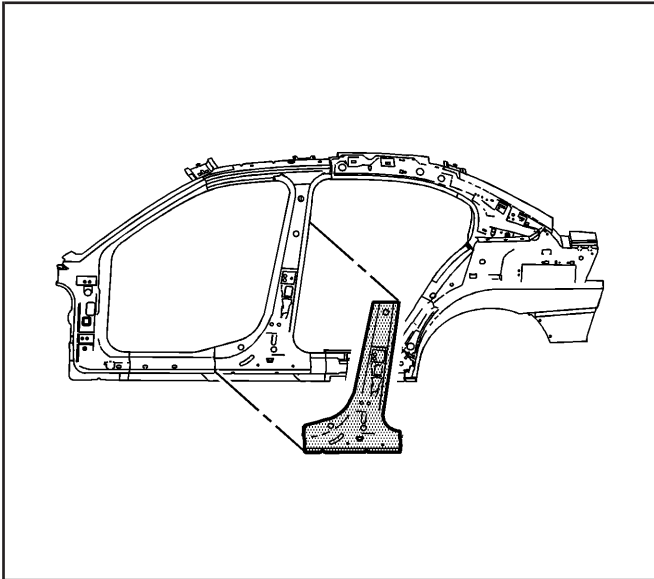

1219547

9. Remove the damaged center pillar.

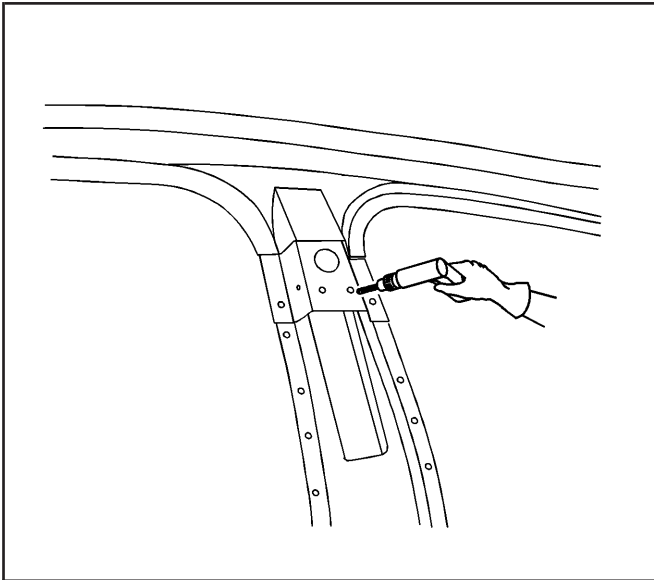

1305032

10. Drill out the 4 spot welds holding the remainder of the reinforcement still on the vehicle.

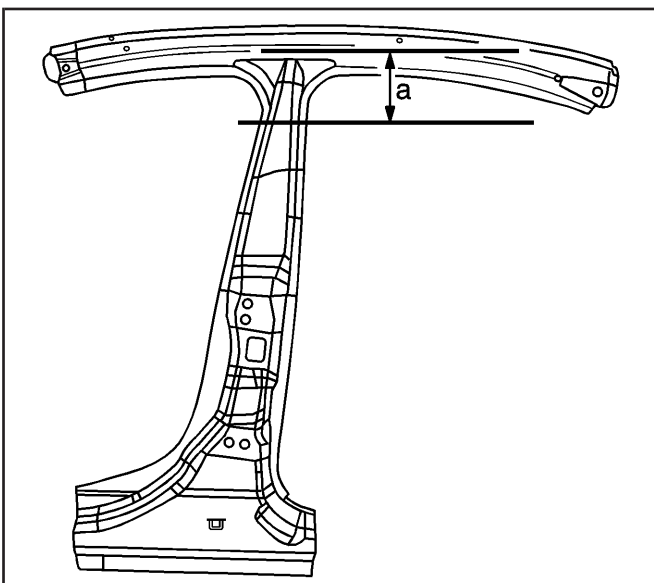

1471608

Installation Procedure

1. To prepare the service part, measure down from the top edge of the upper side frame B-pillar (a) 190 mm (7.5 in). Scribe a line on the center pillar reinforcement service part.

2. Before making the cut, drill the approximately 12 spot welds at the top of the service part. Separate the inner panel from the outer panel. This will allow you to make the cut without cutting into the backing reinforcements.

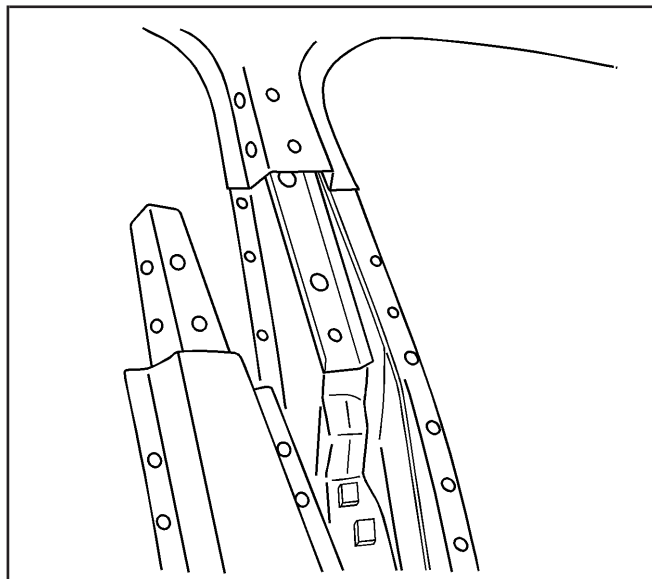

1471554

3. Use a flat-bladed tool to separate the inner reinforcement from the outer reinforcement. With the clearance made, the cut can be made without damage to the inner reinforcements.
4. Drill 8 mm (5/16 in) plug weld holes in the service part as necessary in the corresponding locations noted on the original panel.
5. Prepare all mating surfaces for welding as necessary.
6. Apply 3M Weld-Thru Coating P/N 05916 or equivalent to all mating surfaces.

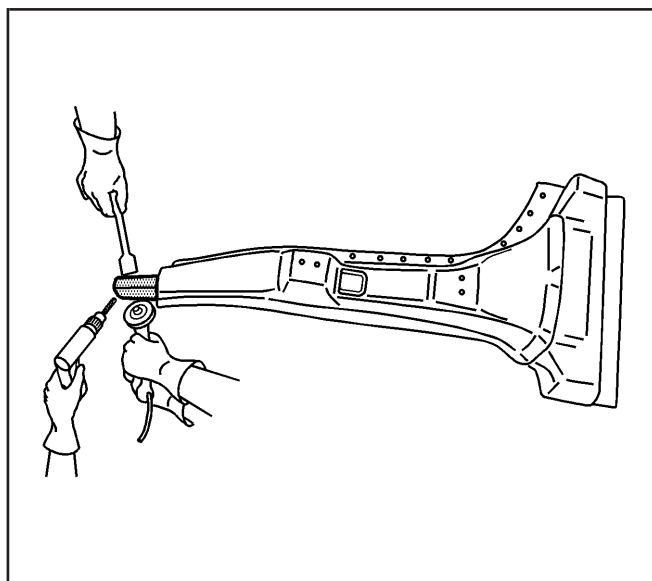

1471550

7. Slide the top sectioning joint together by sliding the service part under the original part at the sectioning area.
8. Position the service part on the vehicle using 3-dimensional measuring equipment. Clamp the part in place.

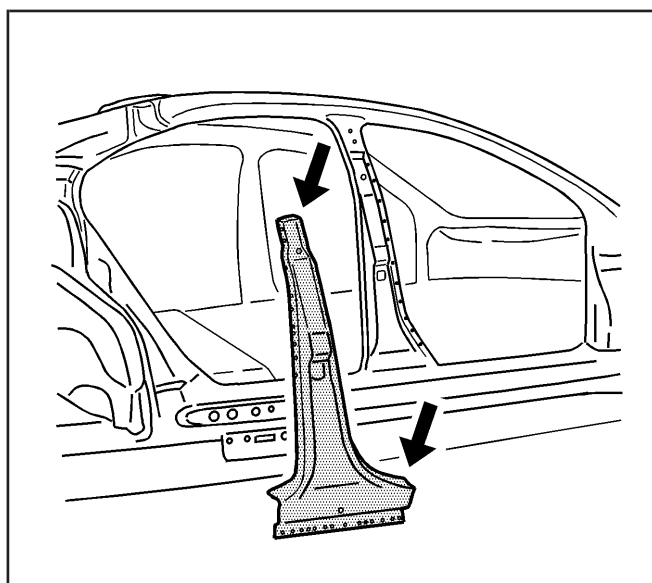

1471545

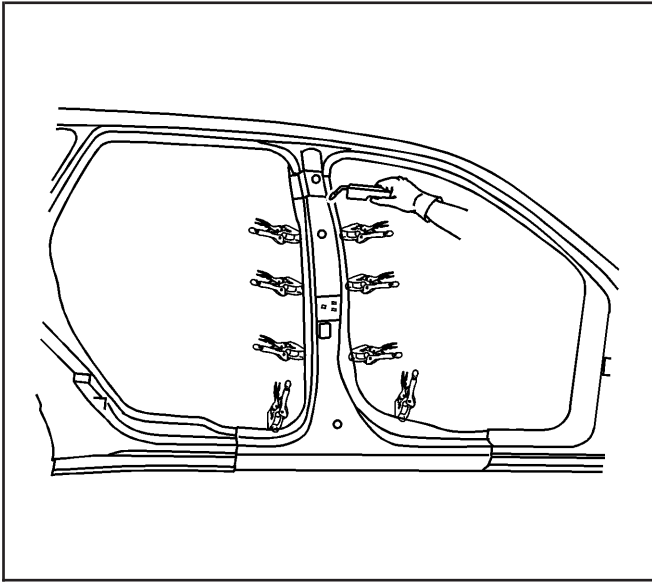

1305241

9. Plug weld accordingly.
 10. To create a solid weld with minimum heat distortion, make 25 mm (1 in) stitch welds along the sectioning joint seam with gaps of 25 mm (1 in). Go back and complete the stitch weld.
 11. Clean and prepare all of the welded surfaces.
 12. Apply the sealers and anti-corrosion materials to the repair area, as necessary. Refer to *Anti-Corrosion Treatment and Repair*.
 13. Paint the repaired area. Refer to *Basecoat/Clearcoat Paint Systems*.
 14. Install all of the related panels and components.
- Caution: Refer to Battery Disconnect Caution on page 1-1.**
15. Connect the negative battery cable.
 16. Enable the SIR system. Refer to *SIR Disabling and Enabling Zones on page 1-129*.