

1318649

Rear Compartment Floor Panel Sectioning (Extended Sedan)

Removal Procedure

Caution: Refer to *Approved Equipment for Collision Repair Caution* on page 1-1.

Caution: Sectioning should be performed only in the recommended areas. Failure to do so may compromise the structural integrity of the vehicle and cause personal injury if the vehicle is in a collision.

1. Disable the SIR system. Refer to *SIR Disabling and Enabling Zones* on page 1-129.

Caution: Refer to *Battery Disconnect Caution* on page 1-1.

2. Disconnect the negative battery cable.

Important: The rear floor pan service part comes as a complete panel. You must make a cut to create the needed part for sectioning.

3. Remove all related panels and components.
4. Remove the sealers and anti-corrosion materials from the repair area, as necessary. Refer to *Anti-Corrosion Treatment and Repair*.
5. Repair as much of the damaged area as possible. Refer to *Dimensions - Body (Sedan)* on page 1-2.
6. Remove the mounting plates (1) on top of the #5 bar floor panel.

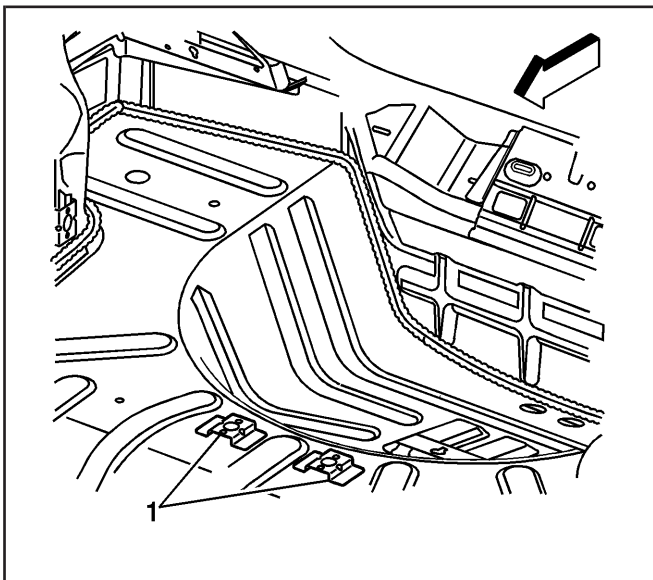

1318653

Important: Do not damage any adjacent panels or components when cutting or drilling out spot welds.

7. Locate the rear edge of cross bar #5 from under the vehicle.
8. Drill several 1/8 in holes in the floor pan only along the rear edge of the rear weld flange of cross bar #5. This will aid in identifying the location from the top side of the floor pan.

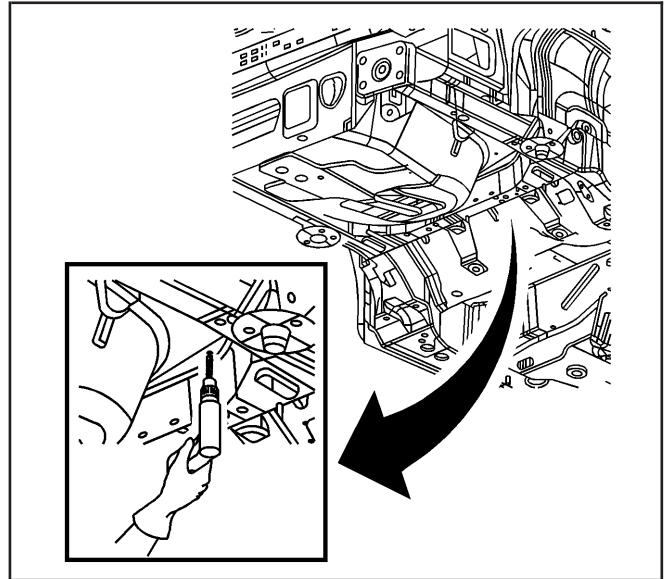

876976

9. Cut the floor panel following the rear edge radius of the #5 bar. Where the #5 bar ends at the rails, cut the radius floor panel straight across.

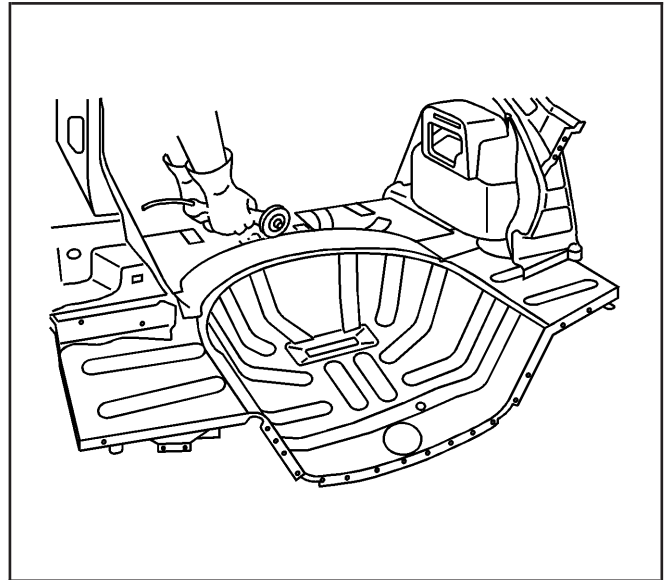

1318660

10. Drill out all the spot welds along rails and the wheelhouses rearward of the cutline and remove the rear compartment floor panel. Note the number and location of welds for installation of the service assembly.

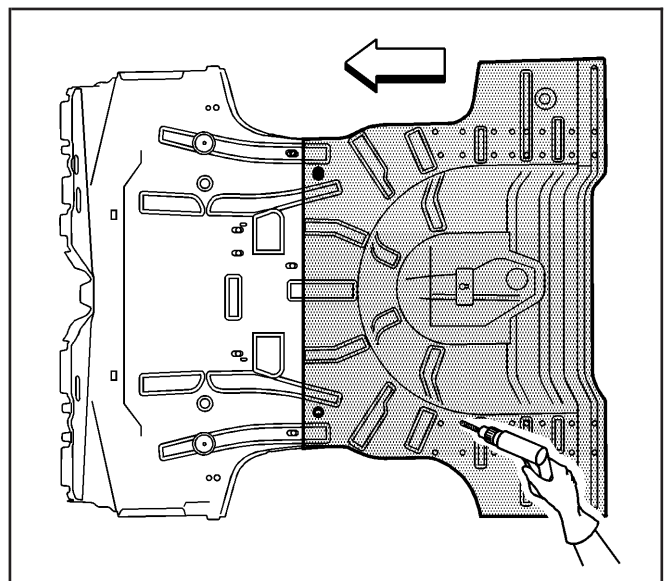

1206912

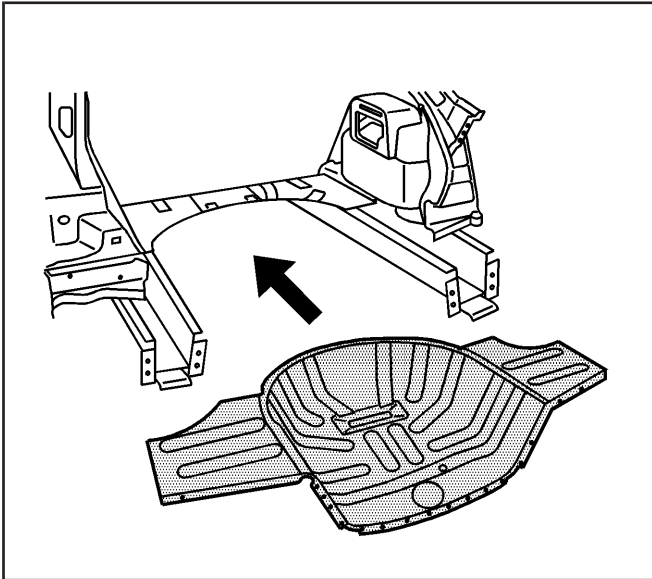

1318662

Important: Do not damage any inner panels or reinforcements.

11. Cut slightly rearward of the #5 bar along the holes drilled in the floor pan. Later, the floor panel will be ground flush to the rear edge of the weld flange.

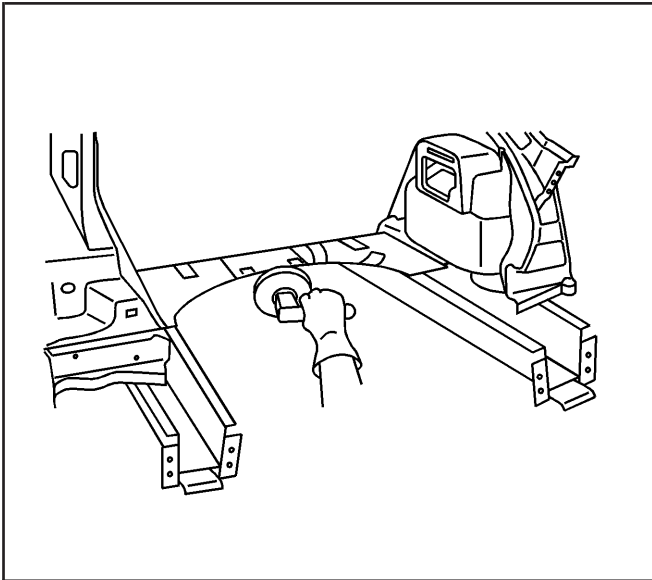

1318664

12. Cut and grind flush the original panel of the rear compartment panel at the rear edge of the #5 crossbar.

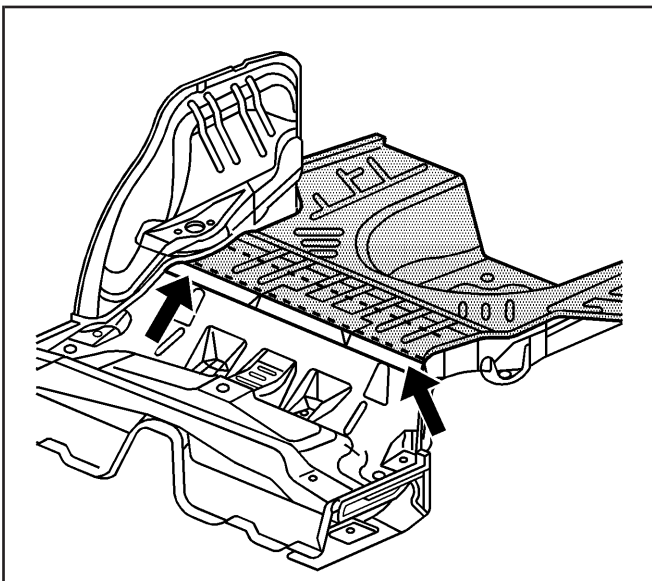

877233

Installation Procedure

1. On the rear compartment floor panel service part, measure from the front edge of the tire tub 200 mm (8 in). Scribe a line across the rear compartment pan.

- Place a piece of masking tape along the top side of the rear compartment floor pan (a).

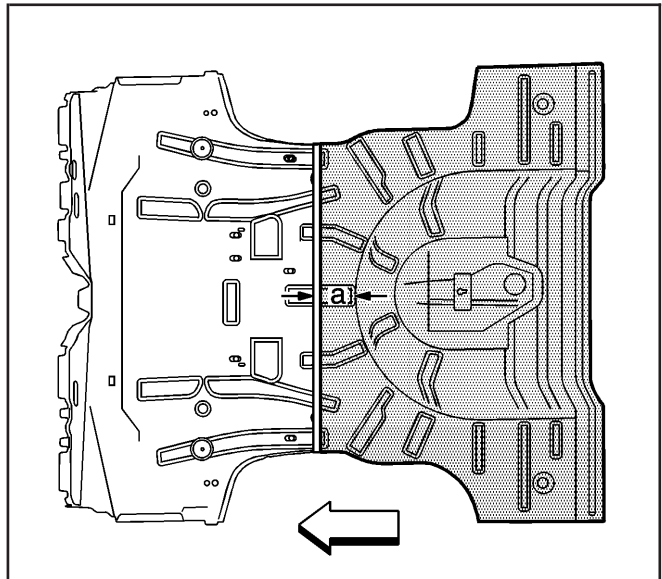

1206916

- Cut along the forward edge of the tape, the edge that would be closest to the front of the #5 bar seat, and remove the rear portion of the panel.
- Drill 8 mm (5/16 in) plug weld holes in the service part as necessary in the corresponding locations noted on the original panel.
- Lay out and drill 2 additional rows of 8 mm (5/16 in) plug weld holes on top of the #5 bar weld flanges.
- Prepare all mating surfaces for welding as necessary.
- Apply 3M Weld-Thru Coating P/N 05916 or equivalent to all mating surfaces.
- Position the rear floor pan to the vehicle using 3-dimensional measuring equipment. Clamp the part in place.

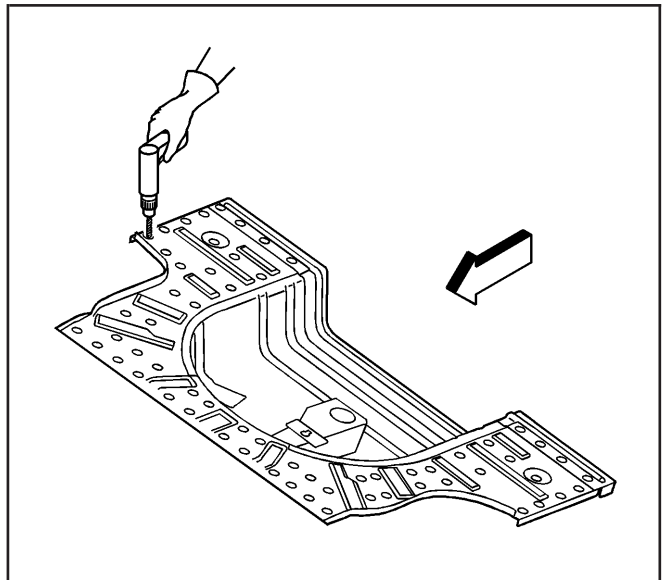

1206925

- Plug weld accordingly.

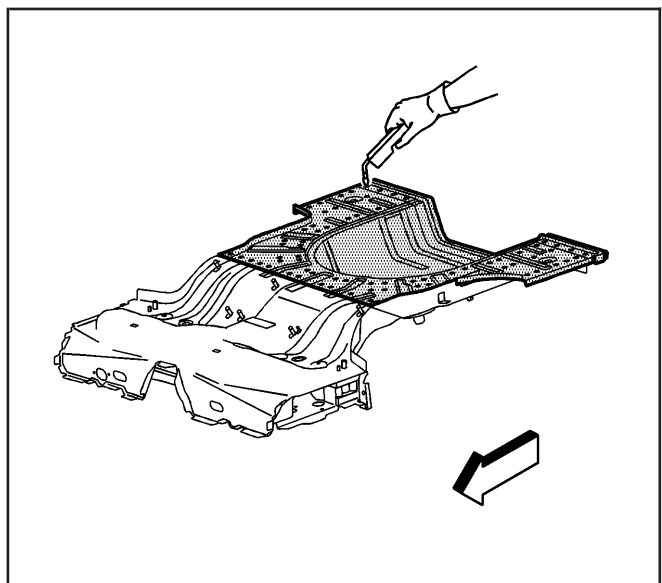

1206931

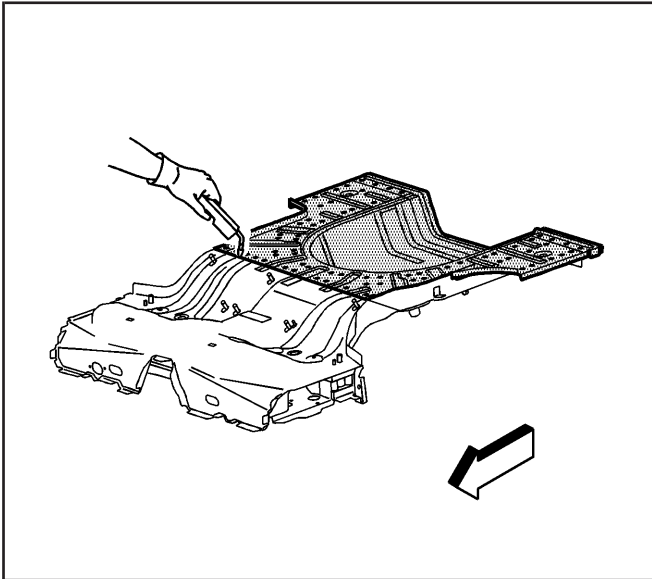

1206932

10. Weld the seam along the front cut edge of the floor panel service part. To create a solid weld along the front of the service part with a minimum of heat distortion, make a stitch weld along the seam with 25 mm (1 in) gaps between each weld.

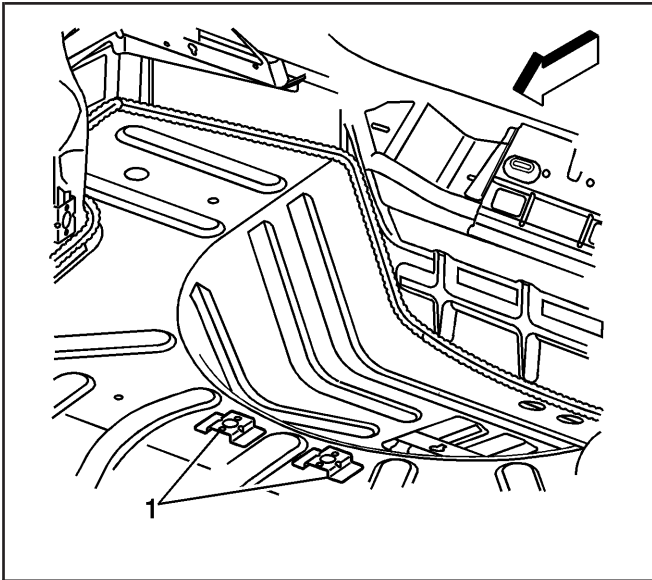

1318653

11. Install the mounting plates (1) on top of the #5 bar floor panel.
 12. Clean and prepare all welded surfaces.
 13. Paint the repaired area. Refer to *Basecoat/Clearcoat Paint Systems*.
 14. Apply the sealers and anti-corrosion materials to the repair area, as necessary. Refer to *Anti-Corrosion Treatment and Repair*.
 15. Install all related panels and components.
- Caution:** Refer to **Battery Disconnect Caution on page 1-1.**
16. Connect the negative battery cable.
 17. Enable the SIR system. Refer to *SIR Disabling and Enabling Zones on page 1-129.*