

1208054

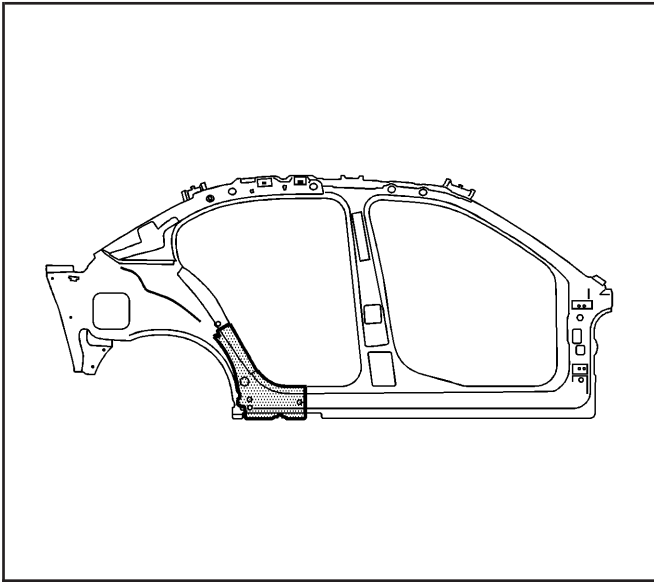

1208057

## Quarter Panel Replacement - Inner

### Removal Procedure

**Caution:** Refer to *Approved Equipment for Collision Repair Caution* on page 1-1.

1. Disable the SIR system. Refer to *SIR Disabling and Enabling Zones* on page 1-129.

**Caution:** Refer to *Battery Disconnect Caution* on page 1-1.

2. Disconnect the negative battery cable.

**Caution:** Sectioning should be performed only in the recommended areas. Failure to do so may compromise the structural integrity of the vehicle and cause personal injury if the vehicle is in a collision.

3. Remove all related panels and components.
4. Restore as much of the damage as possible.
5. Remove the sealers and anti-corrosion materials from the repair area, as necessary. Refer to *Anti-Corrosion Treatment and Repair*.
6. Remove the body inner reinforcement.

**Important:** Do not damage any inner panels or reinforcements.

7. Apply a piece of 50 mm (2 in) tape (a) along the flat area above the outer wheel housing, just below the package shelf mating surface, as shown. This is your sectioning location.
8. In the rocker panel area, measure 40 mm (1.5 in) rearward from the rear 25 mm locating hole as shown (b). Scribe a line. This is your sectioning location.

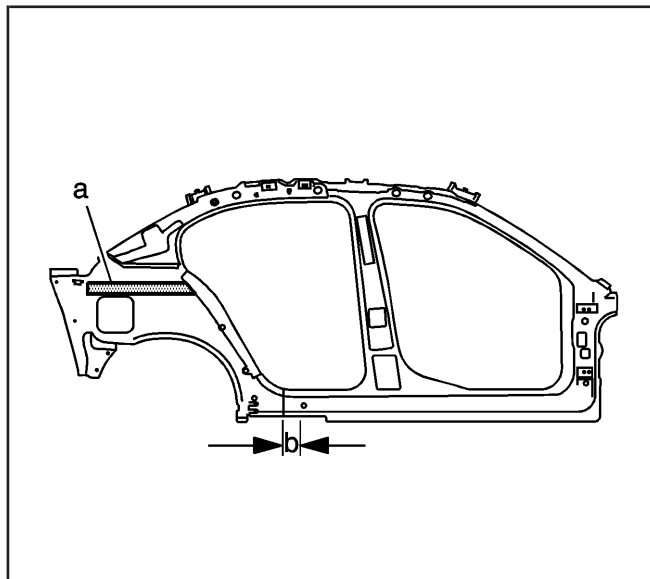

1367141

9. Cut the panel to be sectioned.

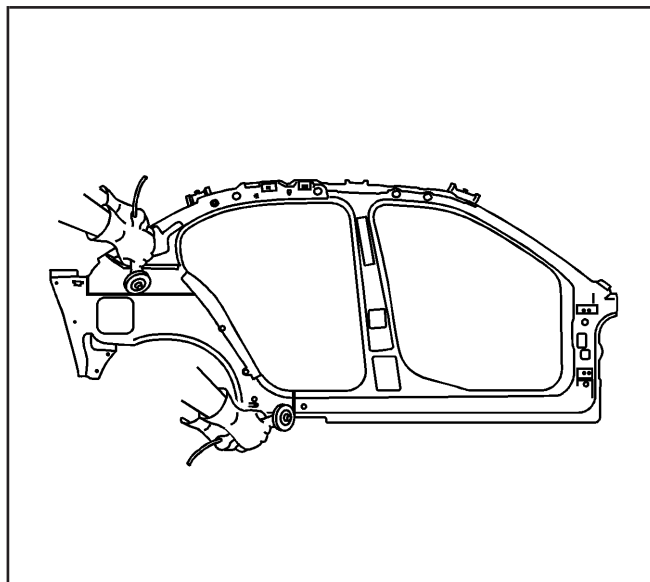

1367145

**Important:** Note the number and location of the factory welds for installation of the inner quarter panel.

10. Locate, mark, and drill out all the necessary factory welds.

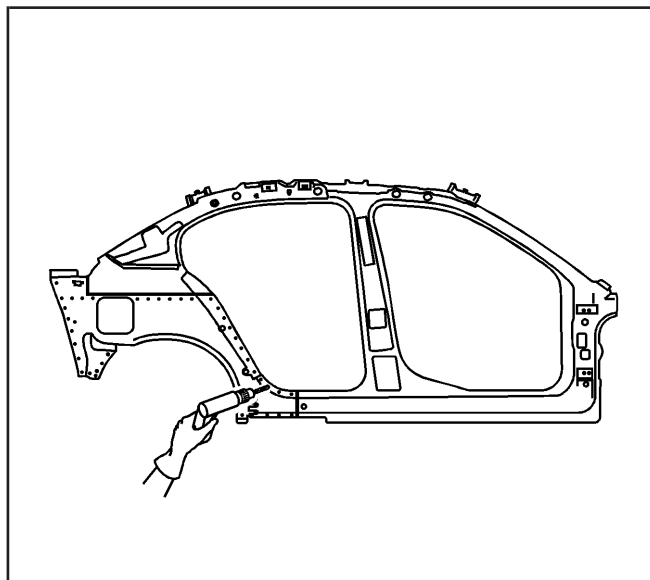

1208075

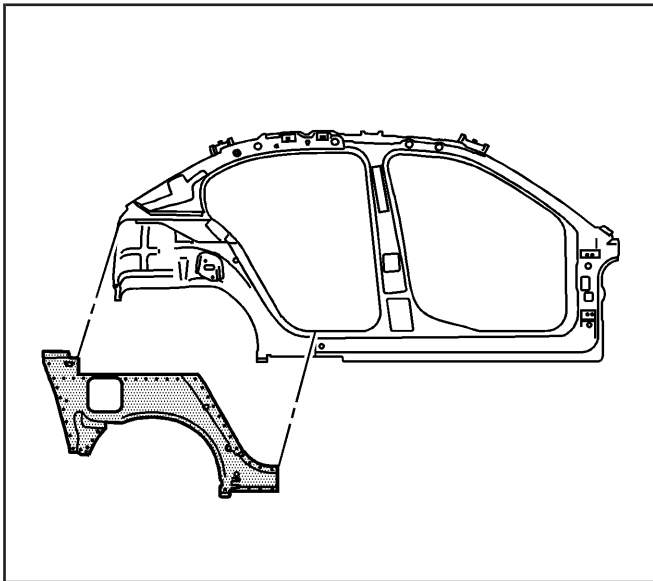

1208219

11. Remove the damaged wheelhouse section.

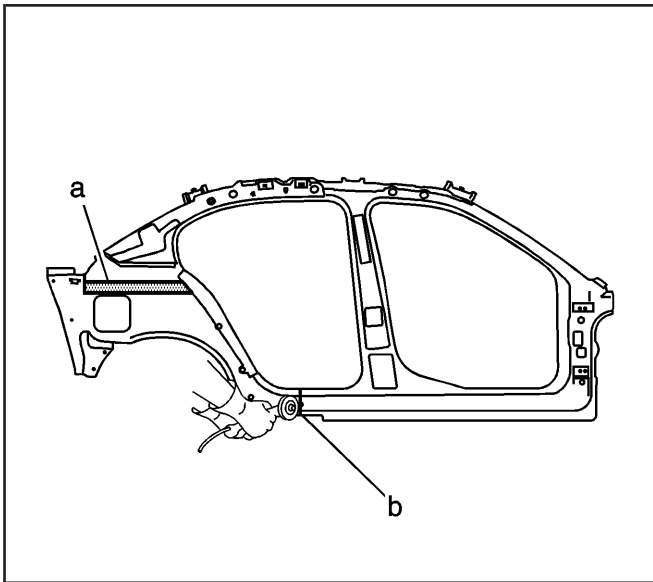

1367147

### Installation Procedure

1. Cut the service part in the corresponding locations to the sectioning cuts. Allow for a 50 mm (2 in) overlap at the wheelhouse.
2. Apply 50 mm (2 in) masking tape above the flat area of the wheel house. Cut on the top edge of the masking tape (a) to correspond with the mating surface of the package shelf extension.
3. Scribe a line. Cut the panel (b) in a straight vertical line through the 25 mm locating hole.

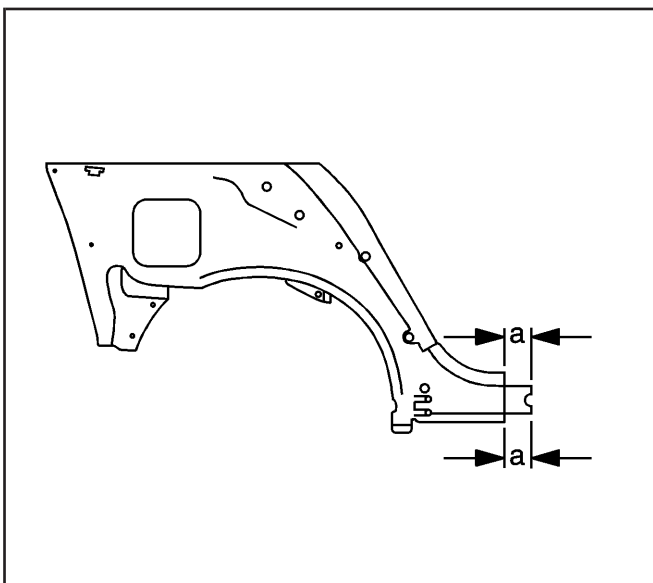

1367151

4. At the cut edge of the service rocker panel, measure rearward 50 mm (2 in) (a). Notch out the rocker panel flange to allow the underlap to the extension rocker.

5. Drill 8 mm (5/16 in) plug weld holes along the sectioning cut on the original reinforcement. Locate these holes 25 mm (1 in) from the edge and spaced 40 mm (1½ in) apart.

**Important:** If the location of the original plug weld holes can not be determined, space the plug weld holes every 40 mm (1 1/2 in) apart.

6. Drill 8 mm (5/16 in) plug weld holes in the service reinforcement as necessary in the locations noted from the original panel.
7. Prepare all mating surfaces as necessary.
8. Apply 3M Weld-Thru Coating P/N 05913 or equivalent to all mating surfaces.

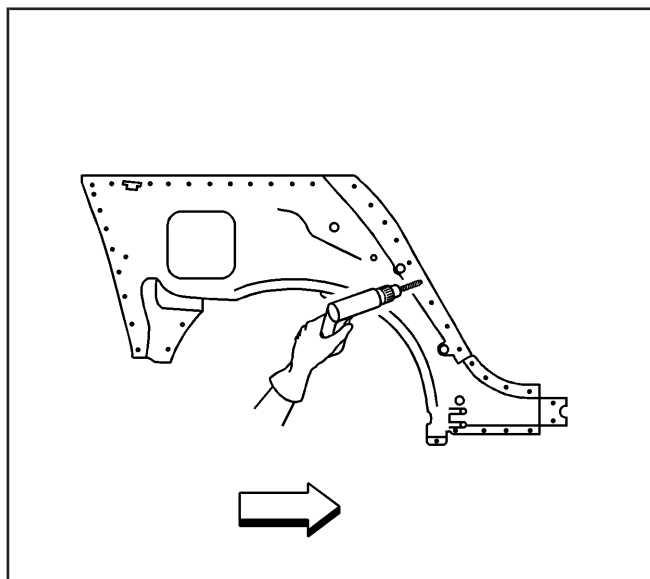

1367157

9. Align the service part on the vehicle using 3-dimensional measuring equipment.

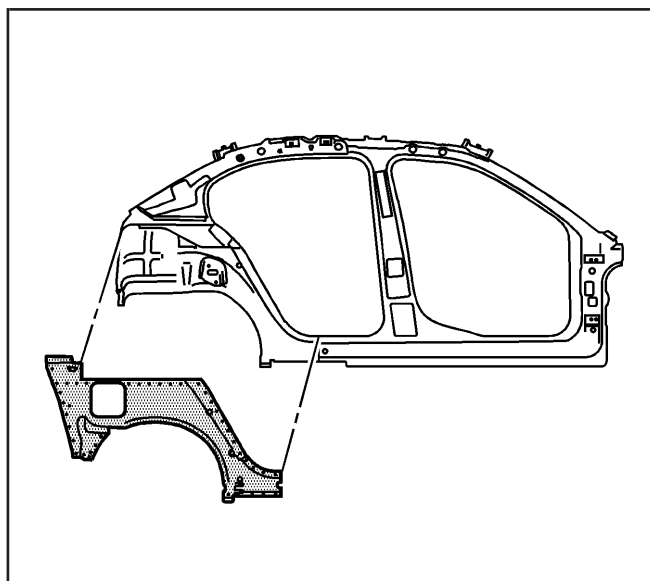

1367195

10. Plug weld accordingly.

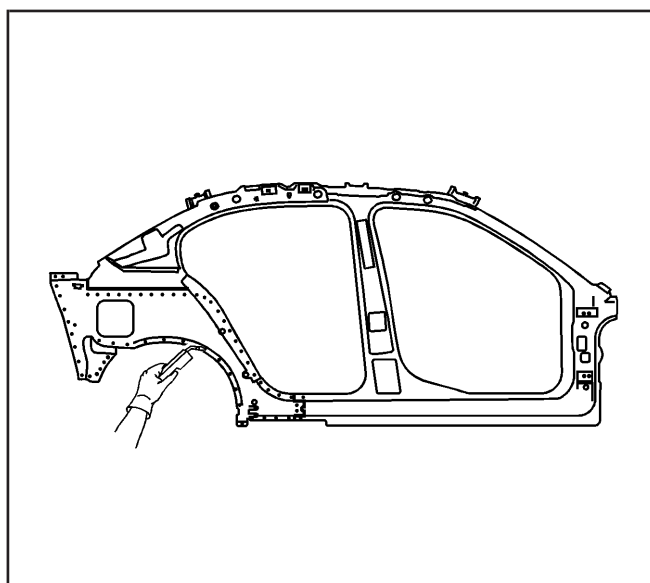

1367202

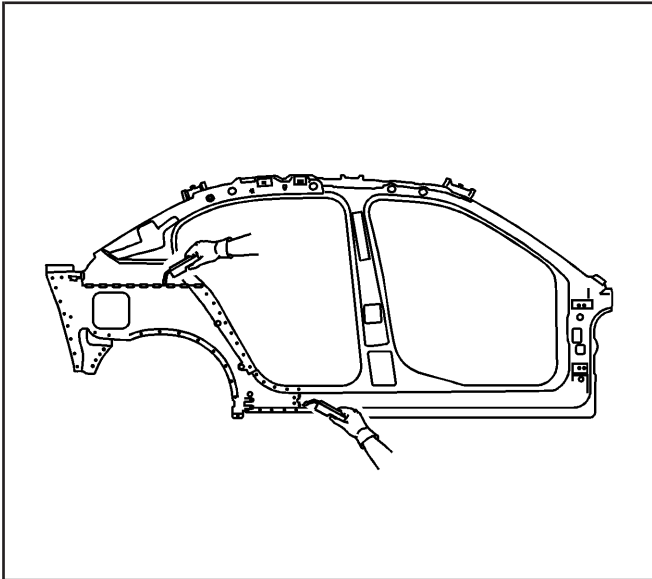

1367204

11. To create a solid weld with minimum heat distortion, make 25 mm (1 in) stitch welds along the seam with 25 mm (1 in) gaps between them. Go back and complete the stitch weld.

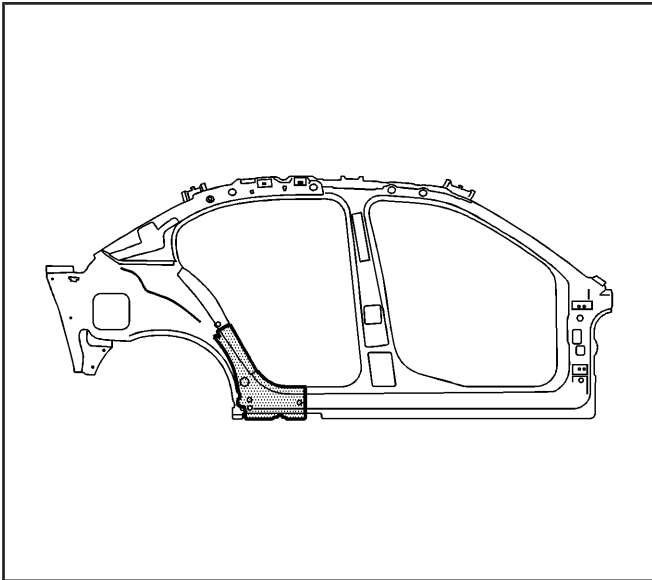

1208057

12. Install the body inner reinforcement.

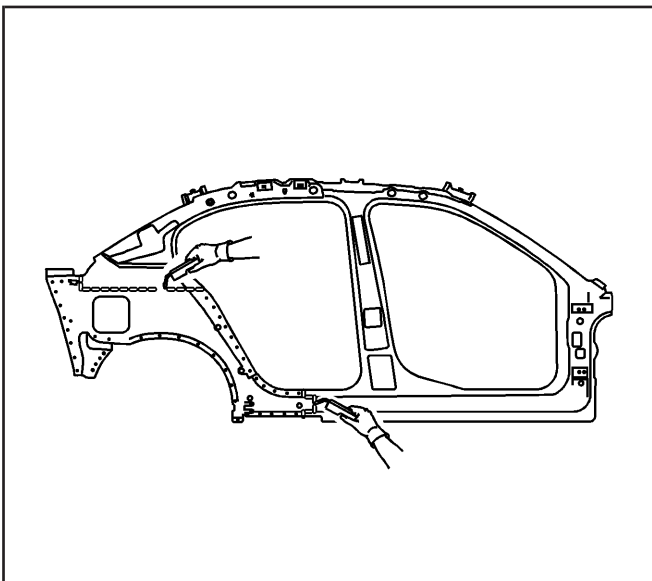

1208260

13. Clean and prepare all of the welded surfaces.
14. Apply the sealers and anti-corrosion materials to the repair area, as necessary. Refer to *Anti-Corrosion Treatment and Repair*.
15. Paint the repaired area. Refer to *Basecoat/Clearcoat Paint Systems*.
16. Install all of the related panels and components.  
**Caution: Refer to Battery Disconnect Caution on page 1-1.**
17. Connect the negative battery cable.
18. Enable the SIR system. Refer to *SIR Disabling and Enabling Zones on page 1-129*.