

SIR Disabling and Enabling Zone 6

Disabling Procedure

1. Turn the steering wheel so that the vehicles wheels are pointing straight ahead.
2. Turn the ignition switch to the OFF position.
3. Remove the key from the ignition switch.
4. Locate the body control module (BCM) fuse center then remove fuse center cover.

Important: This inflatable restraint sensing and diagnostic module (SDM) has two fused power inputs. To ensure there is no unwanted SIR deployment, personal injury, or unnecessary SIR system repairs, remove both AIR BAG (IGN) and AIR BAG (BATT) fuses from the BCM fuse center. With the AIR BAG fuses removed and the ignition switch in the ON position, the AIR BAG warning indicator illuminates. This is normal operation, and does not indicate an SIR system malfunction.

5. Locate and remove the AIR BAG (IGN) and AIR BAG (BATT) fuses from the BCM fuse center.
6. To disable the seat belt pretensioner-RF go to step 7. To disable the roof rail module-right go to step 10 and for the side impact sensor (SIS)-Right go to step 13.
7. Remove the lower center pillar trim. Refer to *Garnish Molding Replacement - Center Pillar Lower*.
8. Remove the connector position assurance (CPA) from the seat belt pretensioner-RF connector.
9. Disconnect the seat belt pretensioner-RF connector from the vehicle harness connector.

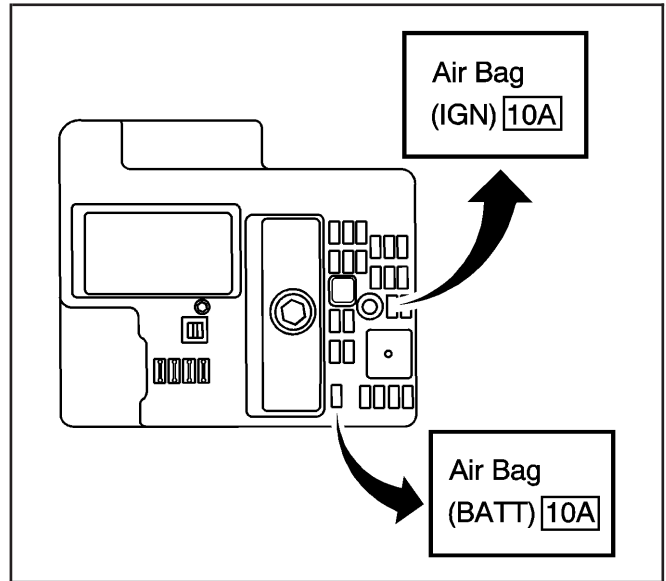

1316302

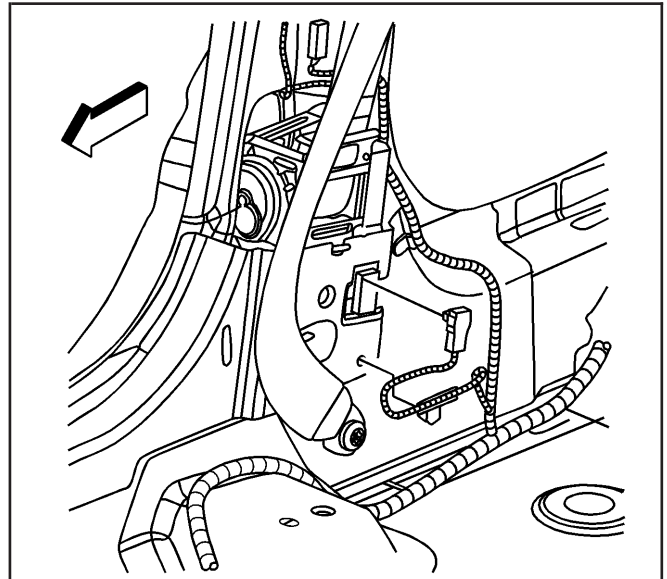

899818

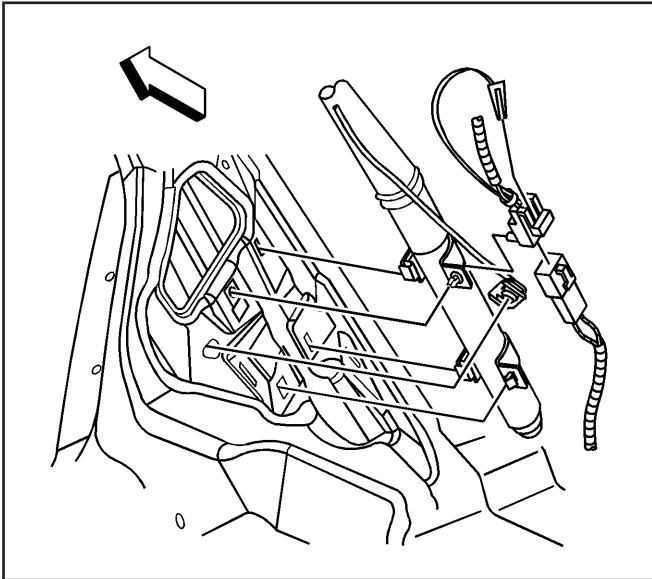

899820

10. Remove the garnish molding from the upper lock pillar. Refer to *Garnish Molding Replacement - Rear Corner Upper*.
11. Remove the CPA from the roof rail module-right connector.
12. Disconnect the roof rail module-right connector from the vehicle harness connector.

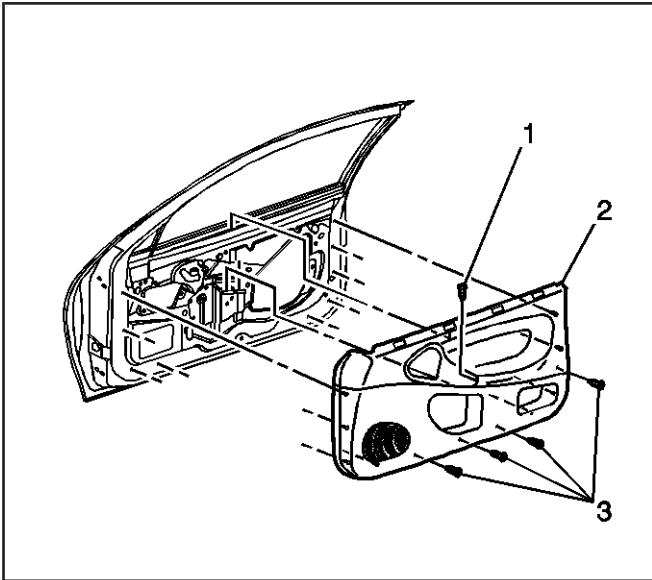

804355

13. Remove the RH door trim panel (2). Refer to *Trim Panel Replacement - Side Front Door*.

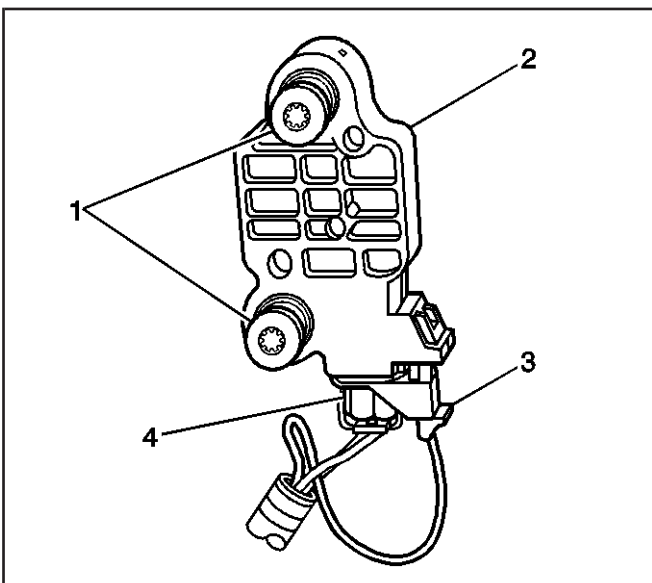

834331

14. Remove the CPA (3) from the SIS-Right connector (4).
15. Remove the SIS-Right connector (4) from the SIS (2).

Enabling Procedure

1. Remove the key from the ignition switch.
2. To enable the SIS-Right go to step 3. To enable the roof rail module-right go to step 7, and to enable the seat belt pretensioner-RF go to step 9.
3. Install the SIS-Right connector (4) to the SIS (2).
4. Install the CPA (3) to the SIS-Right connector (4).

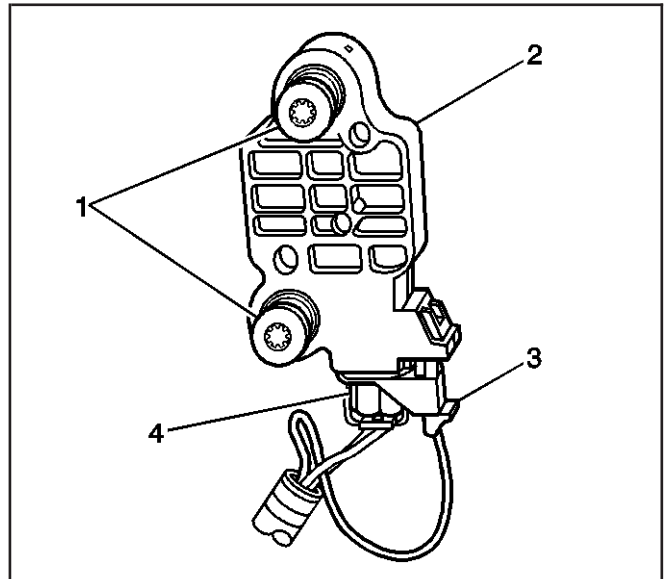

834331

5. Install the RH door trim panel (2). Refer to *Trim Panel Replacement - Side Front Door*.

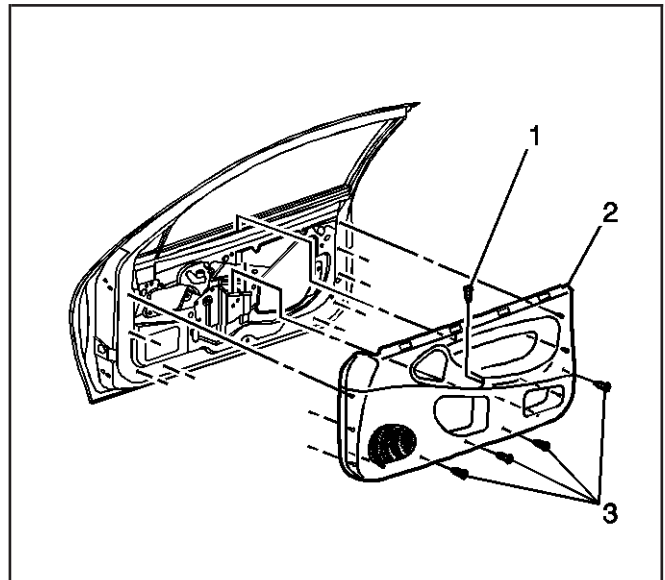

804355

6. Connect the roof rail module-right connector to the vehicle harness connector.
7. Install the CPA to the roof rail module-right connector.
8. Install the garnish molding to the upper lock pillar. Refer to *Garnish Molding Replacement - Rear Corner Upper*.

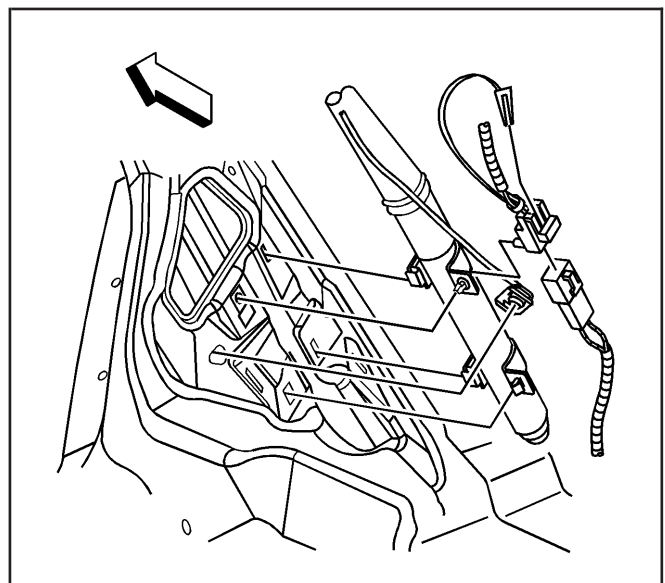

899820

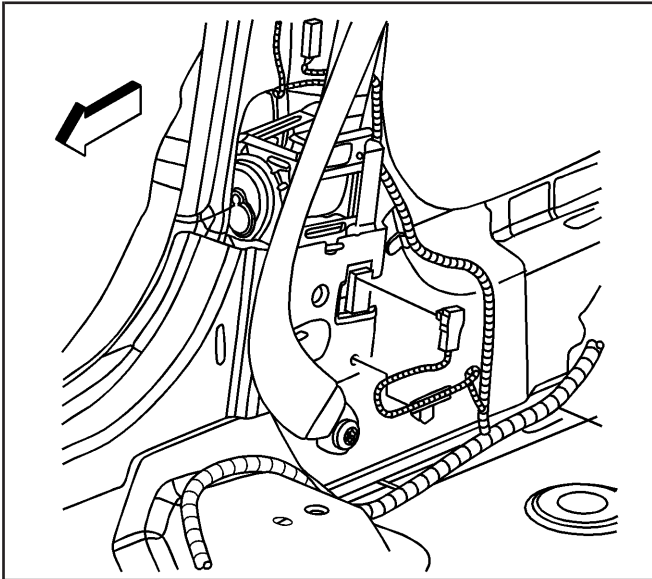

899818

9. Connect the seat belt pretensioner-LF and install the CPA.
10. Install the lower center pillar. Refer to *Garnish Molding Replacement - Center Pillar Lower*.

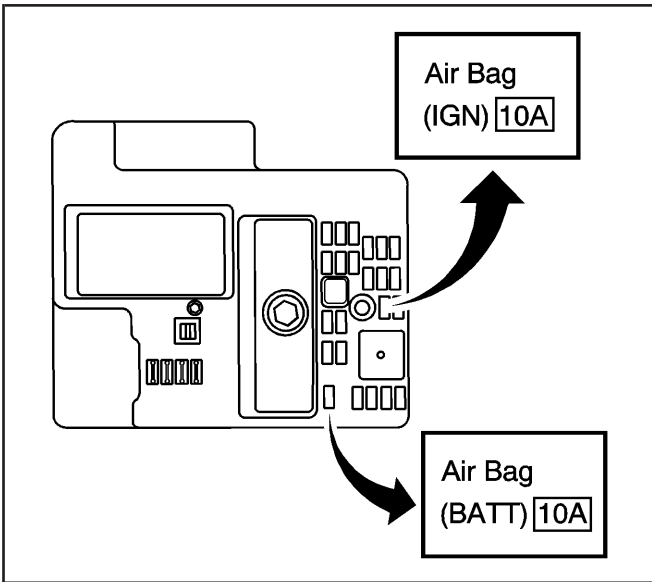

1316302

11. Install the AIR BAG (IGN) and AIR BAG (BATT) fuses into the BCM fuse center.
12. Install the BCM fuse center cover.
13. Use caution while reaching in and turn the ignition switch to the ON position.
The AIR BAG indicator will flash then turn OFF.
14. Perform the Diagnostic System Check – Vehicle if the AIR BAG warning indicator does not operate as described. Refer to *Diagnostic System Check - Vehicle*.