

Front Compartment Front Side Lower Inner Rail Sectioning

Removal Procedure

Caution: Refer to [Approved Equipment for Collision Repair Caution](#) in Cautions and Notices.

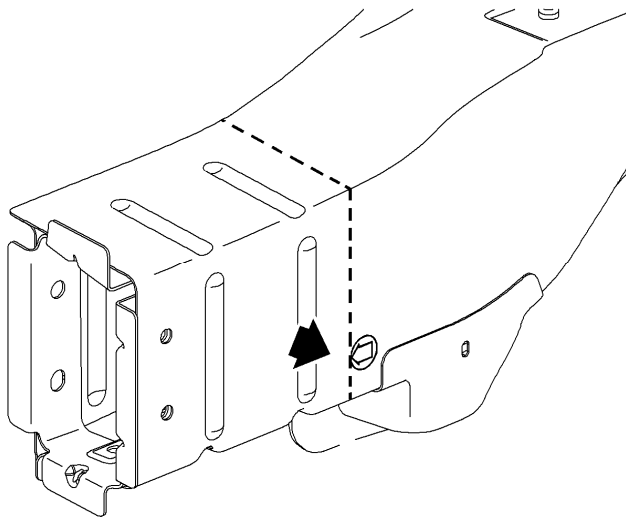

1. Disable the supplemental inflatable restraint (SIR) system. Refer to [SIR Disabling and Enabling](#) in SIR.
2. Disconnect the negative battery cable. Refer to [Battery Negative Cable Disconnection and Connection](#) in Engine Electrical.
3. Remove all related panels and components.
4. Repair as much of the damage as possible to factory specifications. Refer to [Dimensions - Body](#) .
5. Note the location and remove the sealers and anti-corrosion materials from the repair area, as necessary. Refer to [Anti-Corrosion Treatment and Repair](#) in Paint/Coatings.

Important: Do not damage any inner panels or reinforcements.

6. Cut the panel along the front edge of the die mark.
7. Locate and drill out all factory welds. Note the number and location of welds for installation of the front lower inner rail section.
8. Remove the damaged front lower inner rail.

Installation Procedure

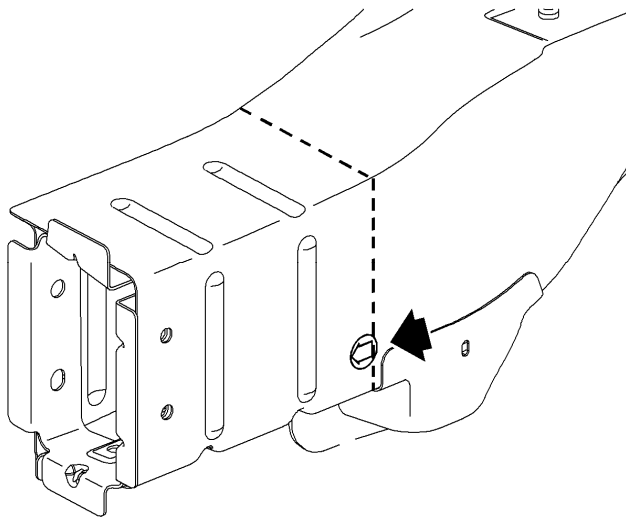

1. Cut the replacement service part along the back edge of the arrow on the die mark.

Important: If the location of the original plug weld holes can not be determined, space the plug weld holes every 40 mm (1 1/2 in) apart.

Some panels may have structural weld-thru adhesive. It is necessary to replace the weld-thru adhesive with an additional spot weld between each factory spot weld.

2. Drill 8-mm (5/16-in) plug weld holes in the service part as necessary in the locations noted from the original panel and along the sectioning cut.
3. Prepare all mating surfaces as necessary.
4. Apply GM-approved Weld-Thru Coating or equivalent to all mating surfaces. Refer to [Anti-Corrosion Treatment and Repair](#).
5. Slide the replacement service part behind the original panel at the sectioning joint.
6. Position the front lower inner rail to the vehicle using 3-dimensional measuring equipment. Clamp the front lower inner rail into place.

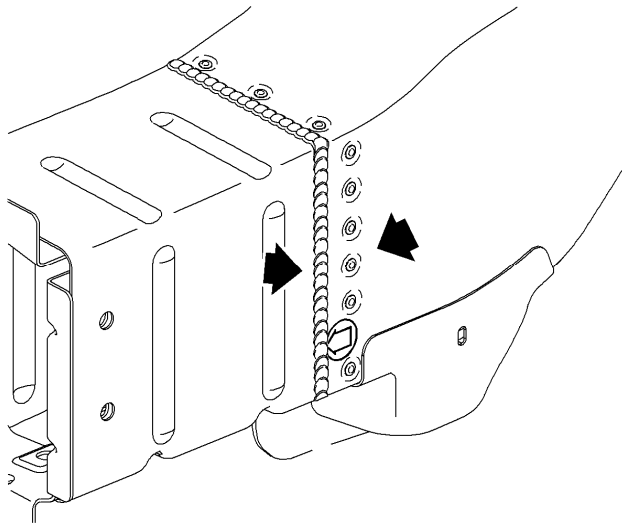

7. Plug weld accordingly.
8. To create a solid weld with minimum heat distortion at the sectioning joint, make 25-mm (1-in) welds with 25-mm (1-in) gaps between them. Then go back and complete the stitch weld.
9. Clean and prepare all welded surfaces.
10. Apply the sealers and anti-corrosion materials to the repair area, as necessary. Refer to [Anti-Corrosion Treatment and Repair](#) in Paint/Coatings.
11. Paint the repair area. Refer to [Basecoat/Clearcoat Paint Systems](#) in Paint/Coatings.
12. Install all related panels and components.
13. Connect the negative battery cable. Refer to [Battery Negative Cable Disconnection and Connection](#) in Engine Electrical.
14. Enable the SIR system. Refer to [SIR Disabling and Enabling](#) in SIR.