

Roof Outer Panel Replacement

Removal Procedure

This repair procedure includes an installation procedure for either metal-inert gas welding or adhesive bonding.

Caution: Refer to [Approved Equipment for Collision Repair Caution](#) in Cautions and Notices.

Important: When replacing panels that involve servicing of stationary windows, refer to [Urethane Adhesive Installation of Stationary Windows](#) in Stationary Windows before performing any priming or refinishing.

1. Disable the supplemental inflatable restraint (SIR) system. Refer to [SIR Disabling and Enabling](#) in SIR.
2. Disconnect the negative battery cable. Refer to [Battery Negative Cable Disconnection and Connection](#) in Engine Electrical.

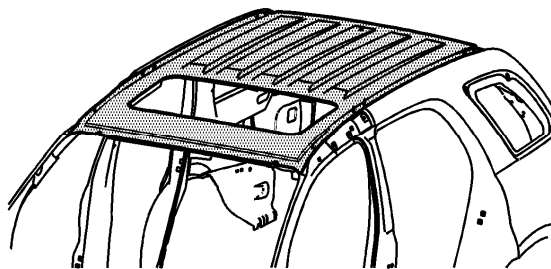

3. Remove all related panels and components.
4. Repair as much of the damage as possible to factory specifications. Refer to [Dimensions - Body](#) .

5. Note the location and remove the sealers and anti-corrosion materials from the repair area, as necessary. Refer to [Anti-Corrosion Treatment and Repair](#) in Paint/Coatings.
6. Remove the windshield. Refer to [Windshield Replacement](#) in Stationary Windows.
7. Remove the liftgate. Refer to [Liftgate Replacement](#) in Body Rear End.

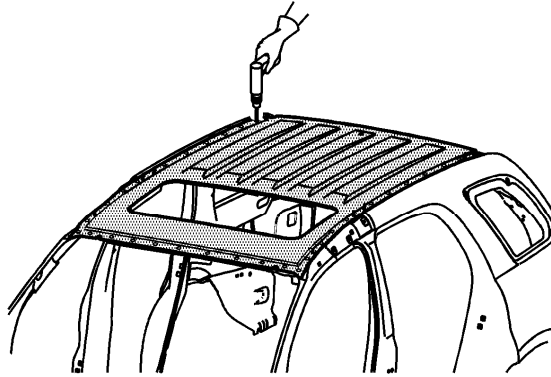

8. Locate and drill out all factory welds. Note the number and location of welds for installation of the roof panel.

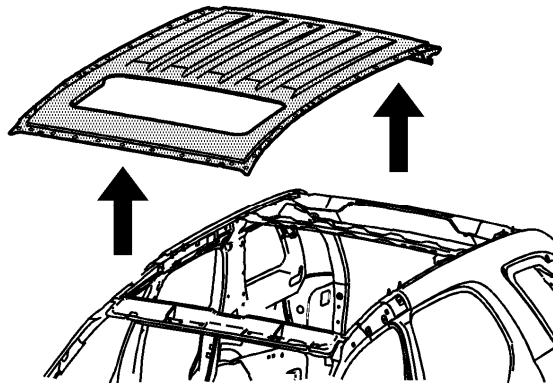

9. With the aid of an assistant, remove the roof panel.

Installation Procedure

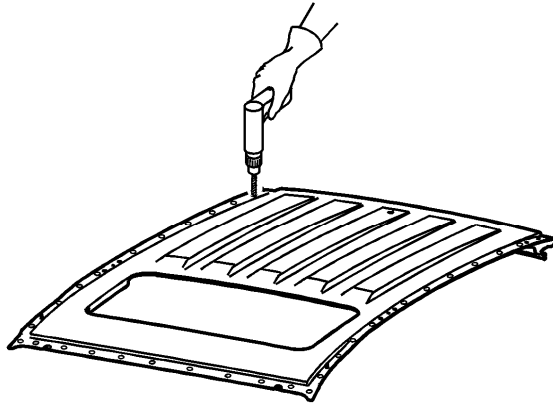

1. Drill 8-mm (5/16-in) plug weld holes as necessary in locations noted from the original panel.

Important: If the location of the original plug weld holes can not be determined, or if structural weld-thru adhesive is present, space the plug weld holes every 40 mm (1½ in) apart.

2. Prepare all mating surfaces as necessary.
3. Apply GM-approved Weld-Thru Coating or equivalent to all mating surfaces. Refer to [Anti-Corrosion Treatment and Repair](#) .

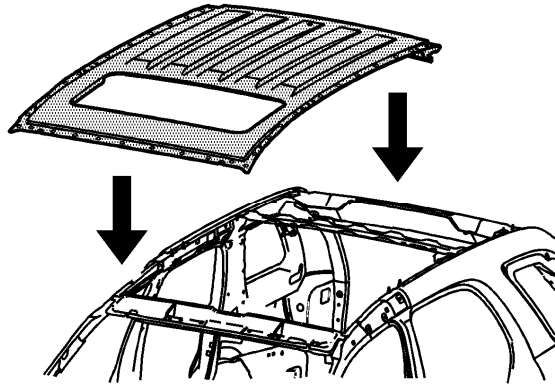

4. With the aid of an assistant, position the roof panel to the body.

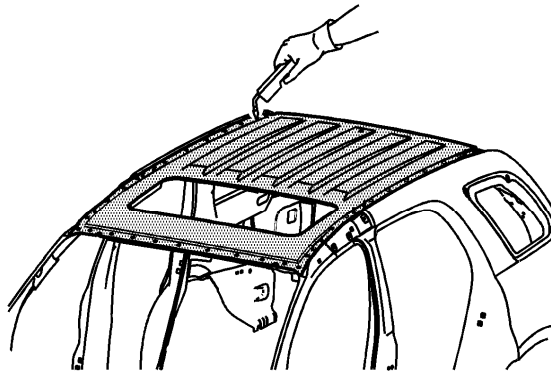

5. Plug weld accordingly.

6. Clean and prepare all welded surfaces.

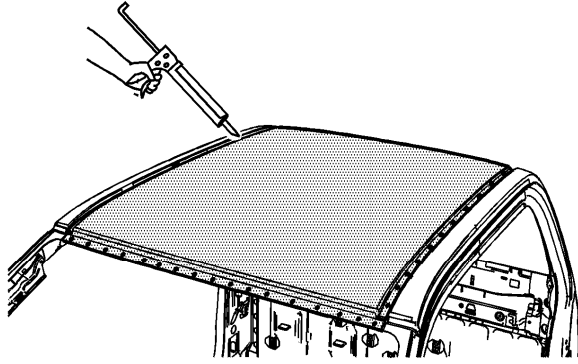

7. Apply the sealers and anti-corrosion materials to the repair area, as necessary.
Refer to [Anti-Corrosion Treatment and Repair](#) in Paint/Coatings.
8. Paint the repair area. Refer to [Basecoat/Clearcoat Paint Systems](#) in Paint/Coatings.
9. Install the windshield. Refer to [Windshield Replacement](#) in Stationary Windows.
10. Install the liftgate. Refer to [Liftgate Replacement](#) in Body Rear End.
11. Install all related panels and components.
12. Connect the negative battery cable. Refer to [Battery Negative Cable Disconnection and Connection](#) in Engine Electrical.
13. Enable the SIR system. Refer to [SIR Disabling and Enabling](#) in SIR.