

Lower Tie Bar Replacement

Removal Procedure

Caution: Refer to [Approved Equipment for Collision Repair Caution](#) in Cautions and Notices.

1. Disable the SIR system. Refer to [SIR Disabling and Enabling](#) in SIR.
2. Disconnect the negative battery cable. Refer to [Battery Negative Cable Disconnection and Connection](#) in Engine Electrical.

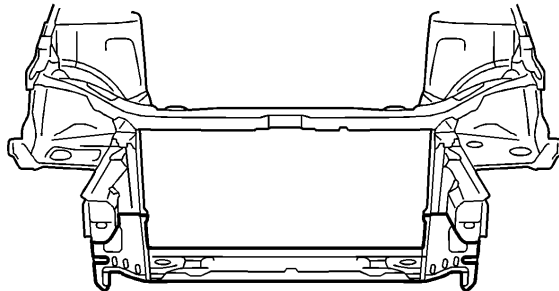

3. Remove all related panels and components.
4. Repair as much of the damage as possible. Refer to [Dimensions - Body](#) .
5. Remove the sealers and anti-corrosion materials from the repair area, as necessary. Refer to [Anti-Corrosion Treatment and Repair](#) in Paint and Coatings.

Important: Note the number and location of the factory welds for installation of the lower tie bar.

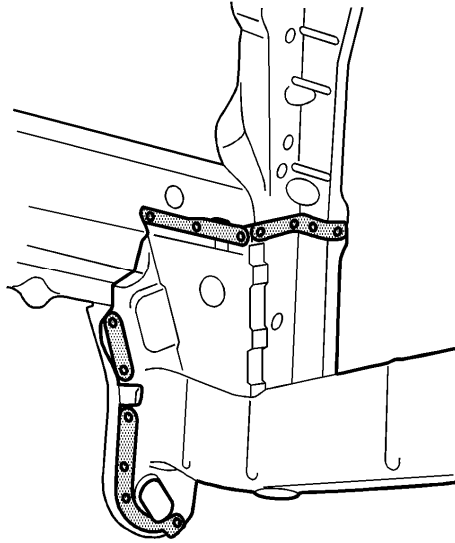

6. Locate and drill out all the necessary factory welds on the inner side of the lower tie bar.

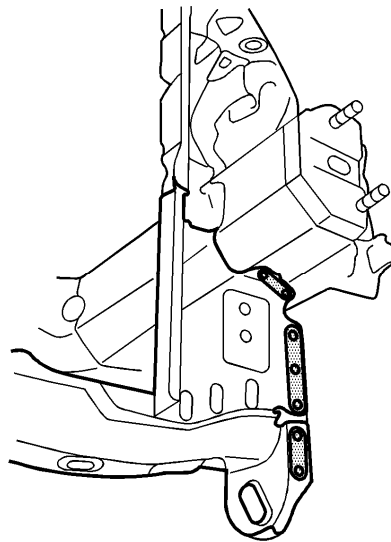

7. Locate and drill out all the necessary factory welds on the outer side of the lower tie bar.

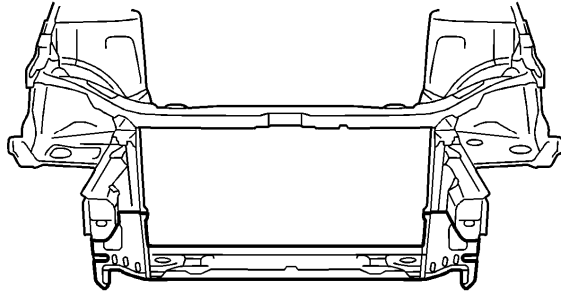

8. Remove the lower tie bar.

Installation Procedure

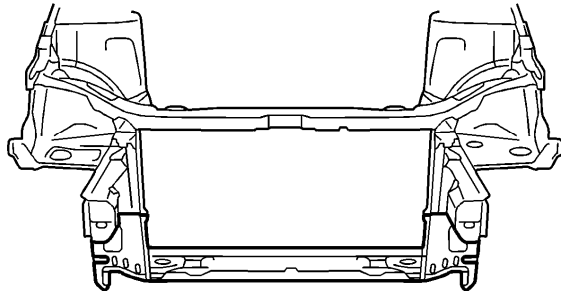

Important: If the location of the original plug weld holes can not be determined, space the plug weld holes every 40 mm (1 1/2 in) apart.

1. Drill 8-mm (5/16-in) plug weld holes in the service part, as necessary, in the locations noted from the original panel.
2. Prepare all mating surfaces as necessary.
3. Apply GM-approved Weld-Thru Coating or equivalent to all mating surfaces. Refer to [Anti-Corrosion Treatment and Repair](#).
4. Position the tie bar on the vehicle using 3-dimensional measuring equipment. Clamp the tie bar into place.

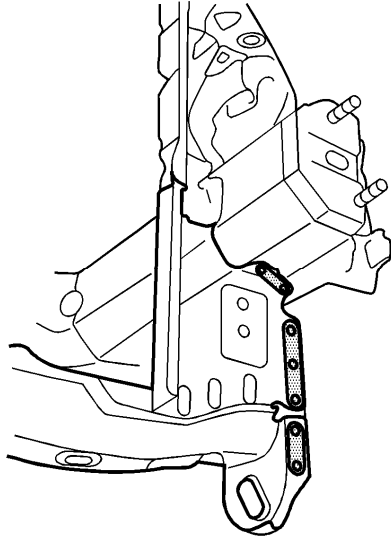

5. Plug weld accordingly on the outer side of the lower tie bar.

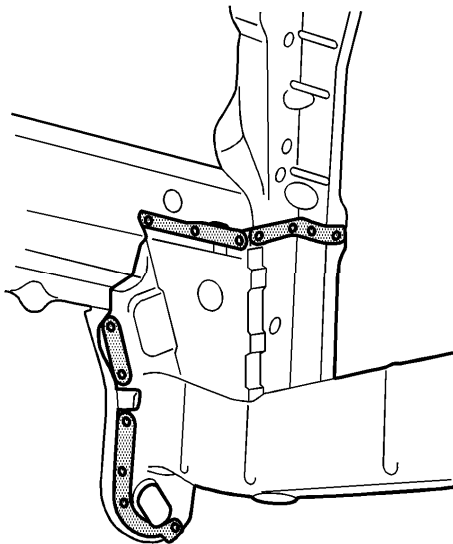

6. Plug weld accordingly on the inner side of the lower tie bar.
7. Clean and prepare all of the welded surfaces.
8. Install all of the related panels and components.

9. Apply the sealers and anti-corrosion materials to the repair area, as necessary. Refer to [Anti-Corrosion Treatment and Repair](#) in Paint and Coatings.
10. Paint the repaired area. Refer to [Basecoat/Clearcoat Paint Systems](#) in Paint and Coatings.
11. Connect the negative battery cable. Refer to [Battery Negative Cable Disconnection and Connection](#) in Engine Electrical.
12. Enable the SIR system. Refer to [SIR Disabling and Enabling](#) in SIR.