

Rail Sectioning - Right Front Lower

Important: If the damage exceeds the recommended area for sectioning and the rail cannot be straightened, the complete rail must be replaced.

Sectioning procedures have been developed to simplify repair of the lower rails, providing the majority of the damage can be returned to factory specifications. Failure to follow the instructions may lead to improper rail sectioning, which may compromise the structural integrity of the vehicle. Be certain to use correct procedure for proper rail sectioning. Left and right side rails have different cut measurements.

Removal Procedure

Caution: Refer to [Approved Equipment for Collision Repair Caution](#) in Cautions and Notices.

1. Disable the SIR system. Refer to [SIR Disabling and Enabling Zones](#) in SIR.
2. Disconnect the negative battery cable. Refer to [Battery Negative Cable Disconnect/Connect Procedure](#) in Engine Electrical.

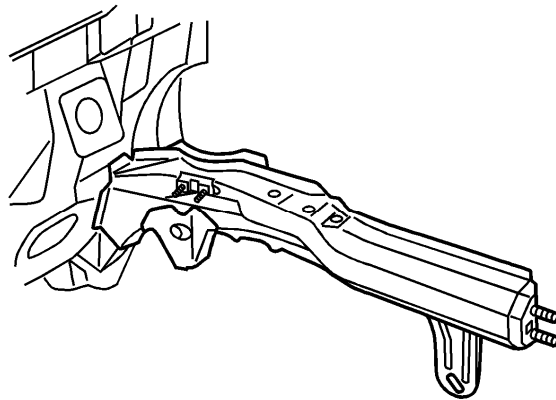

3. Remove all related panels and components.
4. Restore as much of the damage as possible to factory specifications. Refer to [Dimensions - Body](#).

Caution: Refer to [Foam Sound Deadeners Caution](#) in Cautions and Notices.

5. Note the location and remove the sealers and anti-corrosion materials from the repair area as necessary, Refer to [Anti-Corrosion Treatment and Repair](#) in Paint and Coatings.
6. Perform the necessary procedures to gain access to repair. Refer to [Tie Bar Replacement - Upper](#) , [Tie Bar Replacement - Right](#) , [Tie Bar Replacement - Lower](#) .

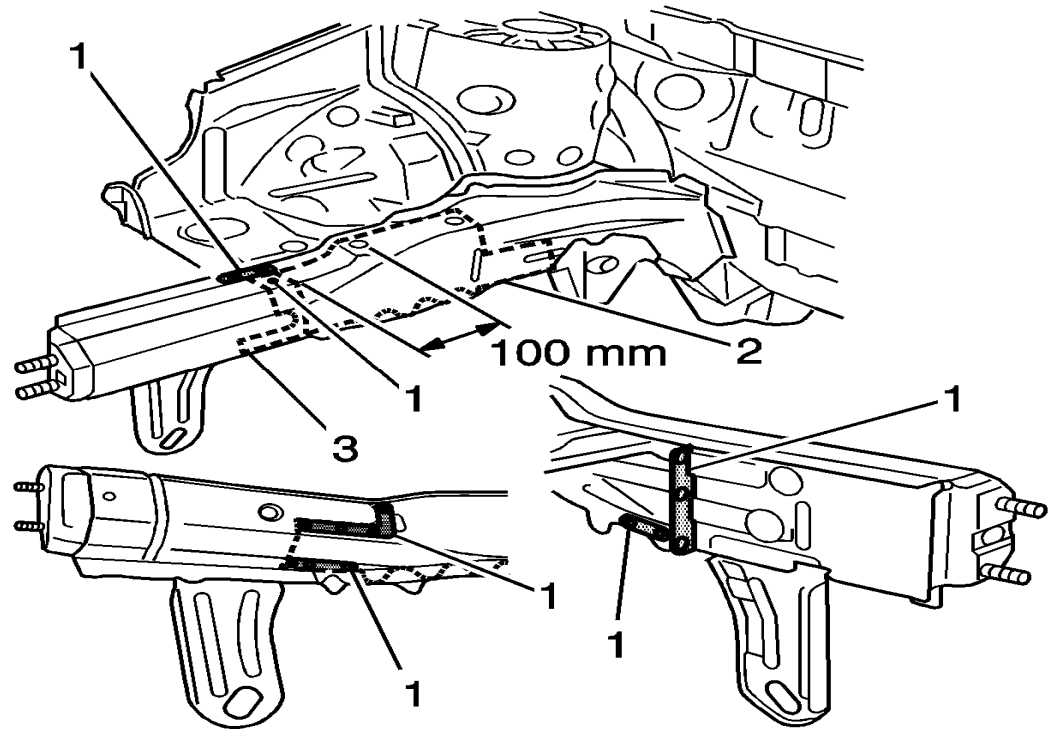

Important: When cutting off the damaged section of the right front lower rail, make sure not to damage the internal reinforcement.

7. Locate, mark, and drill out all factory welds (1) attaching the right front lower rail section.
8. On the top of the rail, locate the first cut-out hole (2). From the middle of the cut-out hole, measure forward 100 mm (3.94 in) and scribe a line, this is the cut location (3).
9. Remove the damaged section of the rail.

Service Part Preparation

1. Clean and prepare mating surfaces as necessary.
2. Apply GM-approved Weld-Thru Coating or equivalent to all mating surfaces. Refer to [Anti-Corrosion Treatment and Repair](#).

3. Drill 8-mm (5/16-in) plug weld holes, as necessary, in the locations noted from the original assembly.

Installation Procedure

1. Position the service part over the original rail.
2. Align and check fit with 3-dimensional measuring. Refer to [Dimensions - Body](#)

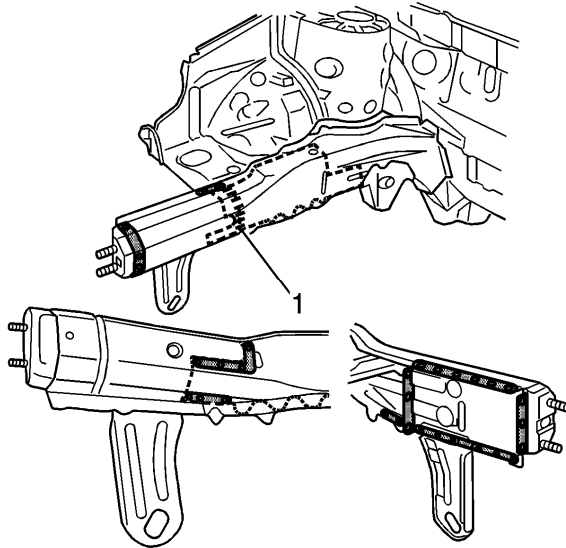

3. When the service assembly is correctly positioned, plug weld accordingly.
 4. Stitch weld along the entire sectioning joint (1).
 5. Make 25 mm (1 in) welds along the seam with 25 mm (1 in) gaps between.
 6. Go back and complete the stitch weld to create a solid weld joint with minimal heat distortion.
 7. Complete the necessary procedures. Refer to [Tie Bar Replacement - Upper](#) , [Tie Bar Replacement - Right](#) , [Tie Bar Replacement - Lower](#) .
 8. Clean and prepare all welded surfaces.
 9. Apply the sealers and anti-corrosion materials to the repair area, as necessary. Refer to [Anti-Corrosion Treatment and Repair](#) in Paint and Coatings.
 10. Paint and repair the area. Refer to [Basecoat/Clearcoat Paint Systems](#) in Paint and Coatings.
 11. Install all related panels and components.
 12. Connect the negative battery cable. Refer to [Battery Negative Cable Disconnect/Connect Procedure](#) in Engine Electrical.
 13. Enable the SIR system. Refer to [SIR Disabling and Enabling Zones](#) in SIR.
-