

# Front Side Door Hinge Replacement

## Removal Procedure

**Caution:** Refer to [Approved Equipment for Collision Repair Caution](#) in the Preface section.

1. Disable the supplemental inflatable restraint (SIR) system.

**Caution:** Refer to [Battery Disconnect Caution](#) in the Preface section.

2. Disconnect the negative battery cable.
3. Remove all related panels and components.
4. Restore as much of the damage as possible to factory specifications. Refer to [Dimensions - Body](#) .
5. Note the location and remove the sealers and anti-corrosion materials from the repair area as necessary. Refer to [Anti-Corrosion Treatment and Repair](#) .
6. Remove the door assembly from the vehicle.
7. Mark the position of the hinge.

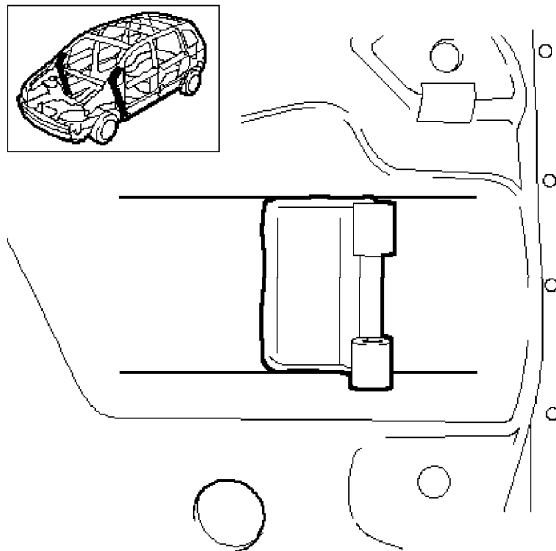

**Important:** Do not damage any inner panels or reinforcements.

8. Locate all factory welds.

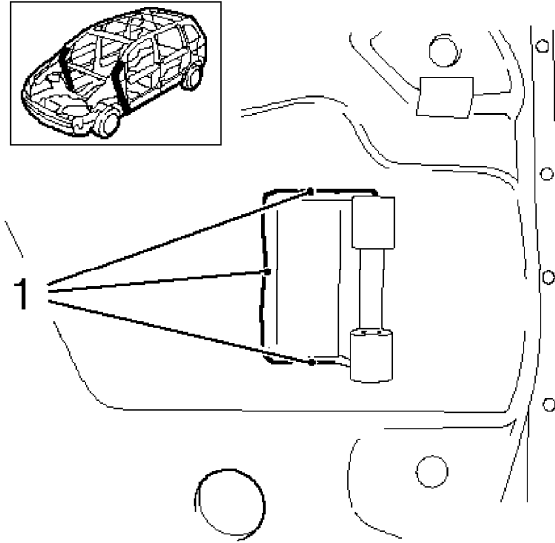

9. Carefully grind the weld (1) from around the body side door hinge.
10. Remove the hinge and grind any remaining weld from the pillar surface in order to ensure a flush fit of the service hinge.

### Installation Procedure

1. Prepare all mating surfaces.
2. Apply GM approved Weld-Thru coating or equivalent to all mating surfaces. Refer to [Anti-Corrosion Treatment and Repair](#) .

3. Position the hinge with prior markings and secure with a suitable tool.

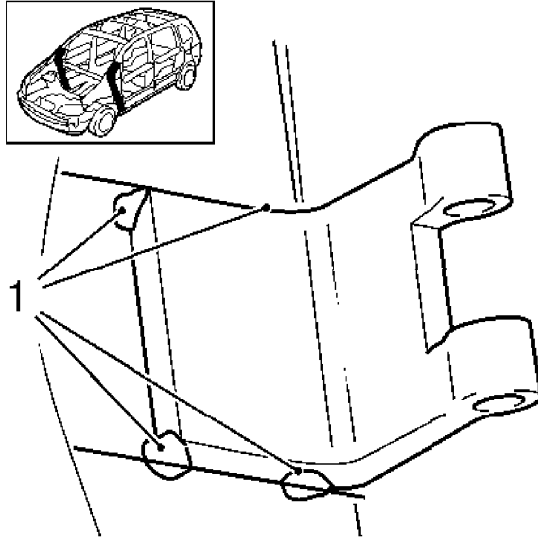

4. MIG tack weld the hinge in the areas noted (1).
5. With the aid of an assistant, position the door assembly to the door opening.

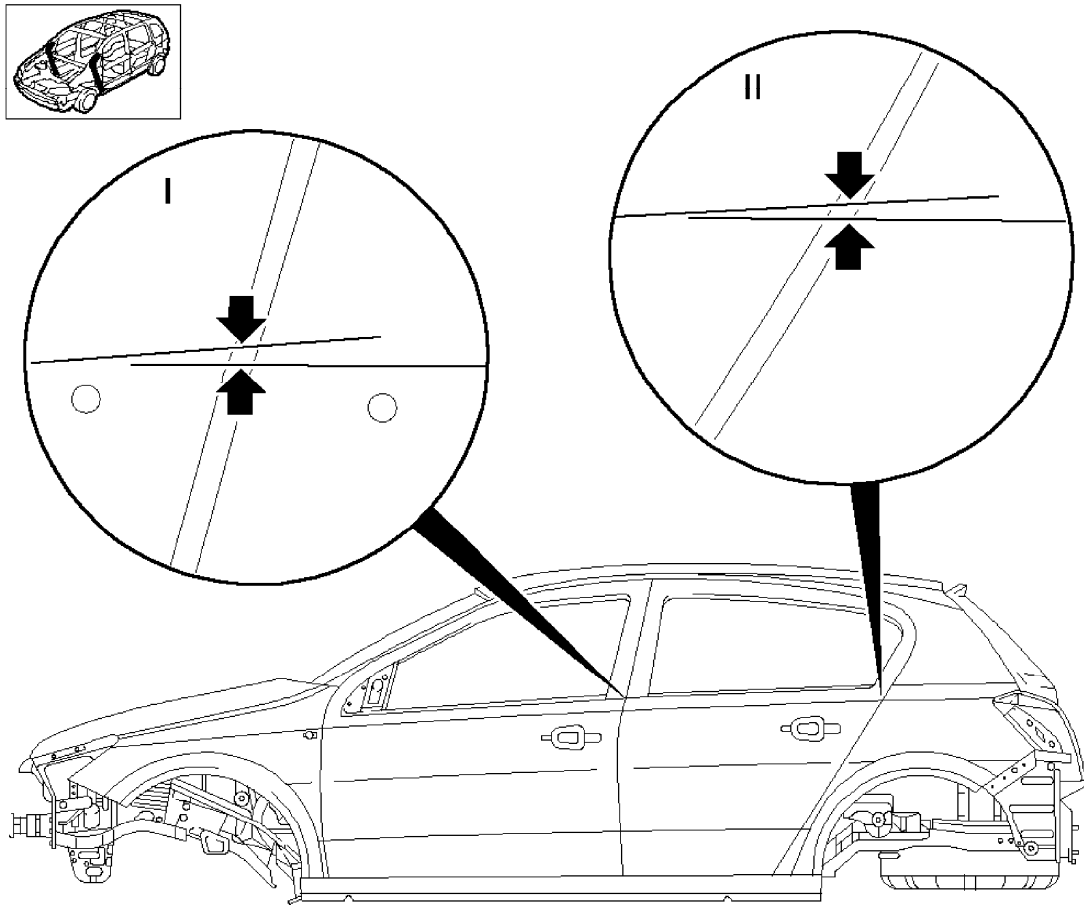

**Important:** The dimensions refer to unpainted doors before completion.

6. Adjust the doors to the position as shown. (I & II) (2.0 +/- 0.5) mm. This increase will allow for the additional weight of the door hardware and trim components.

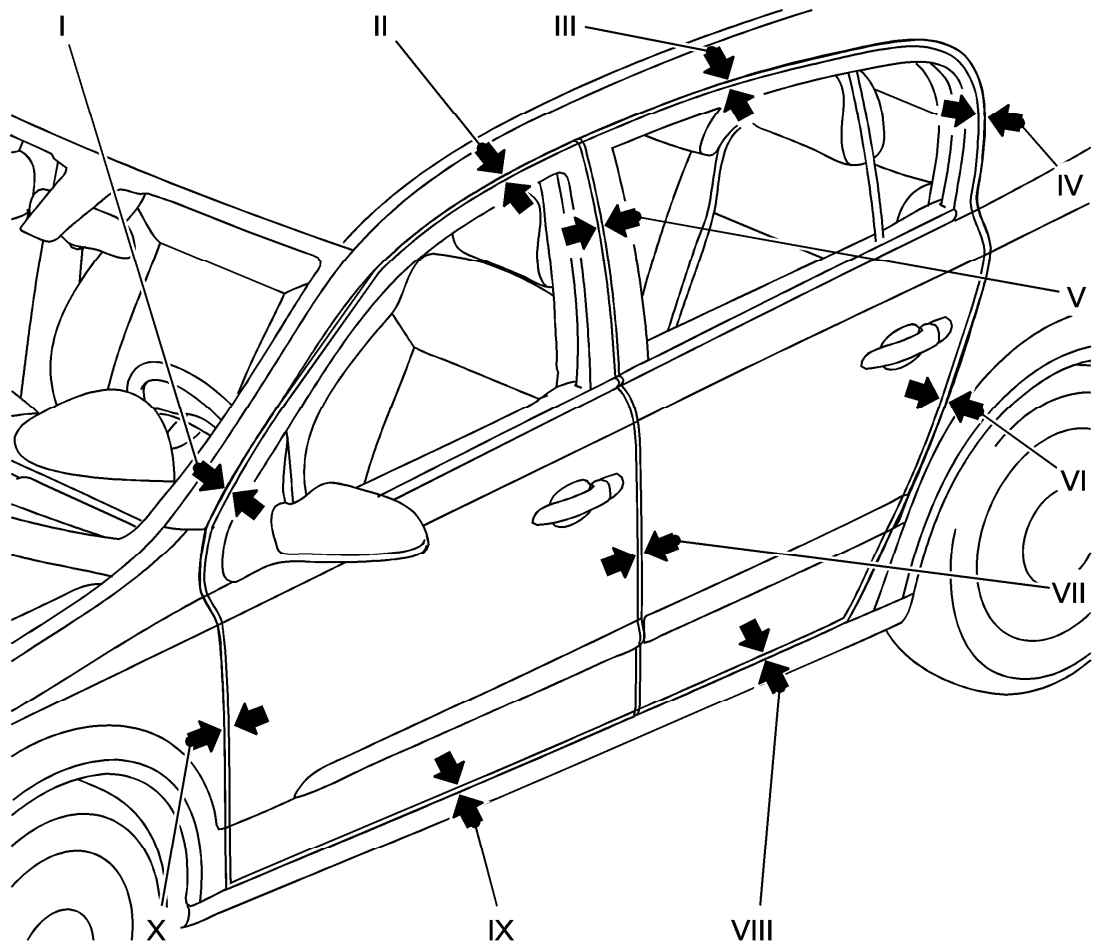

**Important:** The gap specifications refer to unpainted doors before completion with lock and striker installed but without door seals

7. Align door with the following gap specifications.

7.1. Position: I

8. Dimensions in mm: 3.9

9. Tolerance in mm: +/- 1.0

7.2. Position: II

10. Dimensions in mm: 4.5

11. Tolerance in mm: +/- 1.0

7.3. Position: III

- 12. Dimensions in mm: 4.5
- 13. Tolerance in mm: +/- 1.0

7.4. Position: IV

- 14. Dimensions in mm: 4.0
- 15. Tolerance in mm: +/- 1.0

7.5. Position: V

- 16. Dimensions in mm: 3.8
- 17. Tolerance in mm: +/- 0.8

7.6. Position: VI

- 18. Dimensions in mm: 3.8
- 19. Tolerance in mm: +/- 0.8

7.7. Position: VII

- 20. Dimensions in mm: 3.8
- 21. Tolerance in mm: +/- 0.8

7.8. Position: VIII

- 22. Dimensions in mm: 4.5
- 23. Tolerance in mm: +/- 1.0

7.9. Position: IX

- 24. Dimensions in mm: 4.5
- 25. Tolerance in mm: +/- 1.0

7.10. Position: X

- 26. Dimensions in mm: 3.8
- 27. Tolerance in mm: +/- 0.8

28. Remove the door from the vehicle.

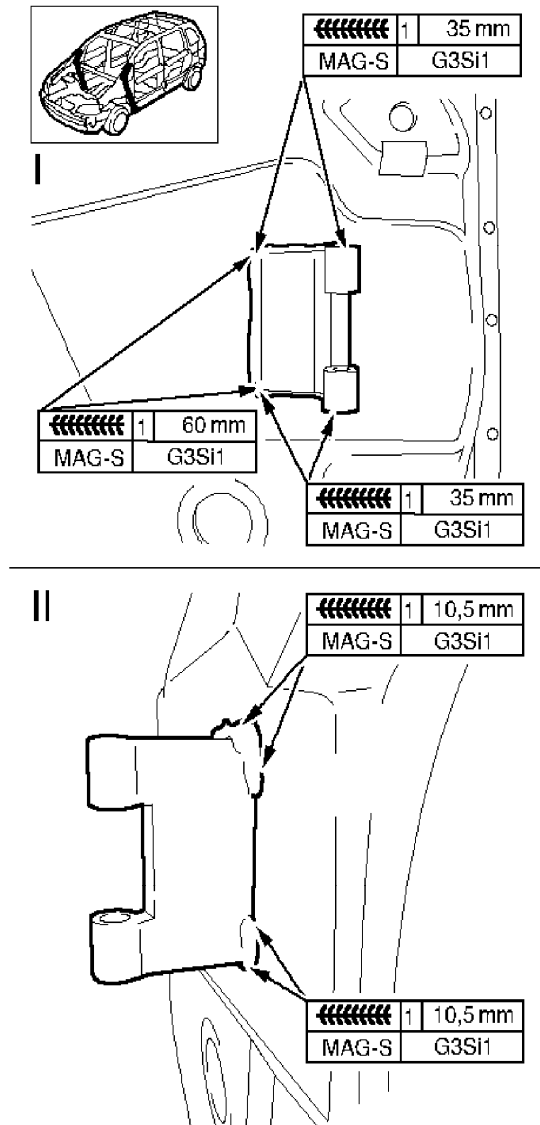

**Important:** To create a solid weld with minimum heat distortion, make a 25 mm (1 inch) stitch weld with 25 mm gaps between. Then go back and complete a solid weld seam.

29. Complete MIG welding doors hinges (I).
30. If replacing front door upper hinge, make an additional weld seam at the rear (II).
31. Clean and prepare all welded surfaces.
32. Apply the sealers and anti-corrosion materials to the repair area as necessary.  
Refer to [Anti-Corrosion Treatment and Repair](#) .

33. Paint the repair area. Refer to [Basecoat/Clearcoat Paint Systems](#) .
  34. Install all related panel and components.
  35. Connect the negative battery cable.
  36. Enable the SIR system.
-