

Quarter Inner Panel Sectioning (Coupe)

Removal Procedure

Caution: Refer to [Approved Equipment for Collision Repair Caution](#) in the Preface section.

Important: Section in specified areas only. Sectioning outside of these areas may compromise the structural integrity of the vehicle. The sectioning procedures have been developed as a more cost-effective alternative to complete replacement.

1. Disable the SIR system.
2. Disconnect the negative battery cable.
3. Remove all related panels and components.
4. Repair as much of the damage as possible to factory specifications. Refer to [Dimensions - Body](#) .
5. Note the location and remove the sealers and anti-corrosion materials from the repair area, as necessary. Refer to [Anti-Corrosion Treatment and Repair](#) .
6. Remove the quarter outer panel. Refer to [Quarter Outer Panel Sectioning](#) .
7. Remove the center pillar reinforcement. Refer to [Center Pillar Sectioning - Inner](#) .

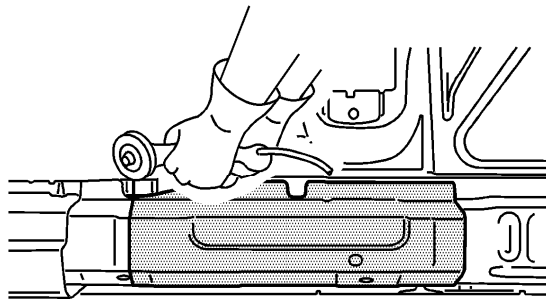

8. Measure approximately 425 mm from the end of the rocker panel reinforcement and mark a vertical line.

Important: If the rocker panel reinforcement is not damaged, set aside to be reused.

9. Cut the panel where sectioning is to be performed.
10. Locate and drill out the factory welds on the rocker panel reinforcement.
11. Remove the rocker panel reinforcement section.

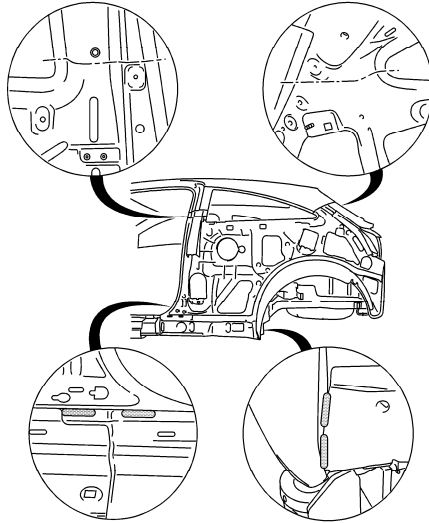

Important: Before cutting the inner quarter panel, the roof frame must be supported with a suitable tool until the panel can be welded in.

12. Section the inner quarter panel as shown.

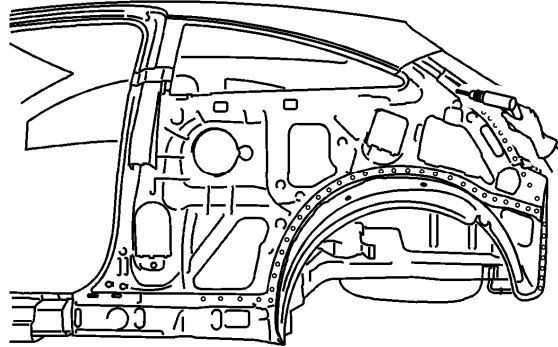

13. Locate and drill out all factory welds. Note locations for installation of the service part.

14. Remove the damaged quarter panel from the vehicle.

Installation Procedure

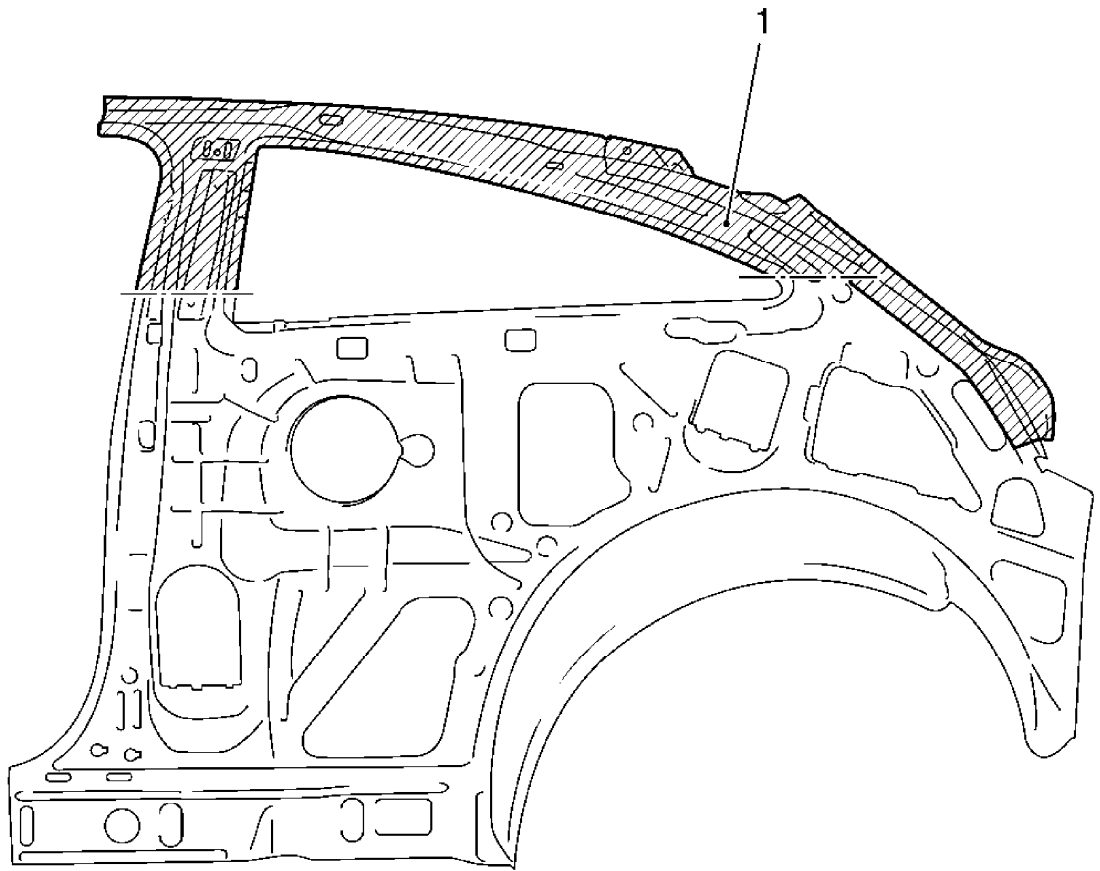

1. Cut the replacement quarter inner panel in corresponding locations to fit the original panel, allowing for a 50 mm (2 in) overlap section.

2. Drill out and discard unused parts (1) from the replacement assembly.

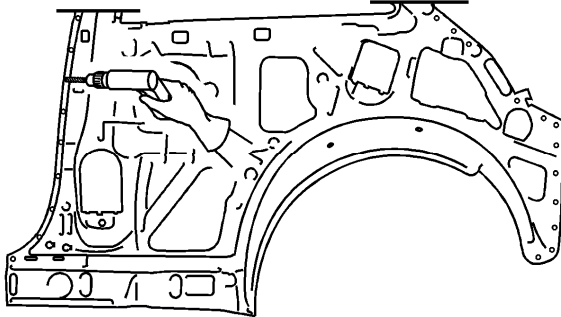

Important: If the location of the original plug weld holes cannot be determined, space the plug weld holes 40 mm (1½ in) apart.

3. Drill 8 mm (5/16 in) plug weld holes in the replacement part as necessary in the locations noted from the original panel.
4. Prepare all mating surfaces as necessary.
5. Apply GM-Approved weld-thru coating or equivalent to all mating surfaces. Refer to [Anti-Corrosion Treatment and Repair](#) .
6. Position the replacement quarter inner panel to the vehicle using 3-dimensional measuring equipment. Clamp in place.

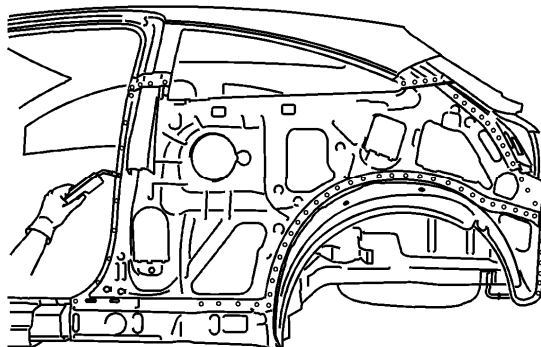

7. Plug weld accordingly.

Important: To create a solid weld with minimum heat distortion, make 25 mm (1 in) stitch welds along the seam with 25 mm (1 in) gaps between them. Then go back and complete the stitch weld.

8. Stitch the weld sectioning joint.

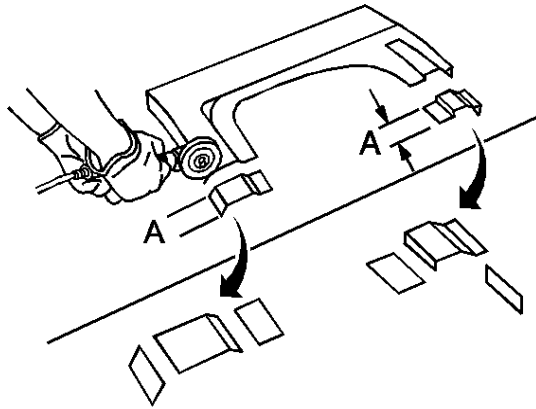

9. Create a 50 mm (2 in) backing plate (A) from the new rocker reinforcement or a similar gauge scrap part if reinforcement is to be reused. Trim the backing plate as necessary to fit behind the sectioning joint where there are no reinforcements.

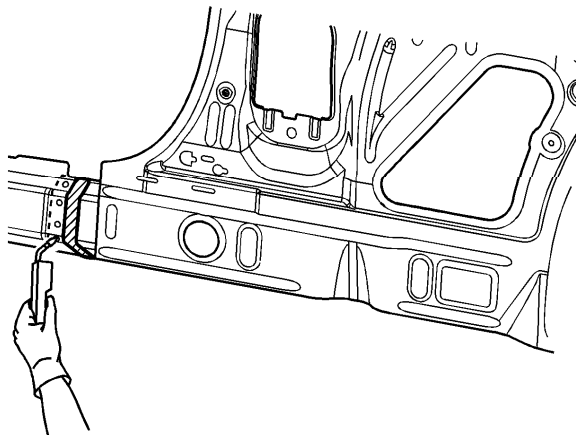

10. Drill 8 mm (5/16 in) plug weld holes along the sectioning joint 13 mm (½ in) from the edge and spaced 40 mm (1½ in) apart.

11. Apply GM-Approved weld-thru adhesive as needed. Refer to [Anti-Corrosion Treatment and Repair](#) .
12. Fit the backing plate halfway into the sectioning joint. Clamp and plug weld accordingly.
13. Drill 8 mm (5/16 in) plug weld holes along the edge of the rocker reinforcement. Locate the holes 13 mm (½ in) from the edge and spaced 40 mm (1½ in) apart.
14. Apply GM-Approved weld-thru adhesive as needed. Refer to [Anti-Corrosion Treatment and Repair](#) .

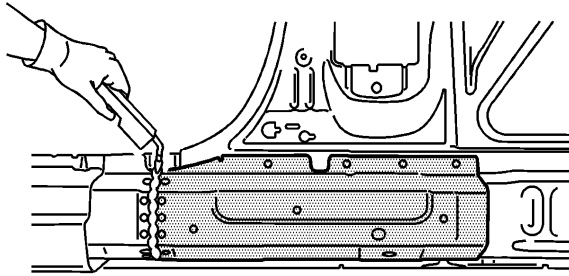

15. Position the rocker reinforcement section to the vehicle. Clamp and plug weld accordingly.

Important: To create a solid weld with minimum heat distortion, make 25 mm (1 in) stitch welds along the seam with 25 mm (1 in) gaps between them. Then go back and complete the stitch weld.

16. Stitch the weld sectioning joint.
 17. Install the center pillar reinforcement. Refer to Center [Pillar Sectioning - Inner](#) .
 18. Install the quarter outer panel. Refer to [Quarter Outer Panel Sectioning](#) .
 19. Prepare all welded surfaces as necessary.
 20. Apply the sealers and anti-corrosion materials to the repair area, as necessary. Refer to [Anti-Corrosion Treatment and Repair](#) .
 21. Paint and repair the area. Refer to [Basecoat/Clearcoat Paint Systems](#) .
 22. Install all related panels and components.
 23. Connect the negative battery cable.
 24. Enable the SIR system.
-

