

# Quarter Inner Panel Sectioning (Sedan)

## Removal Procedure

**Caution:** Refer to [Approved Equipment for Collision Repair Caution](#) in the Preface section.

**Important:** Section in specified areas only. Sectioning outside of these areas may compromise the structural integrity of the vehicle. The sectioning procedures have been developed as a more cost-effective alternative to complete replacement.

**Important:** When replacing panels that involve servicing of stationary glass, refer to [Full-Cut Method Description](#) before performing any priming or refinishing.

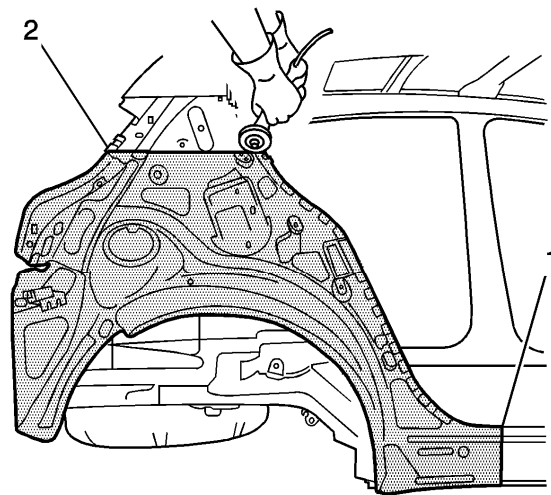

1. Disable the SIR system.
2. Disconnect the negative battery cable.
3. Remove all related panels and components.
4. Remove the quarter outer panel. Refer to [Quarter Outer Panel Sectioning](#) .

5. Repair as much of the damage as possible to factory specifications.

**Caution:** Refer to [Foam Sound Deadeners Caution](#) in the Preface section.

6. Note the location and remove the sealers and anti-corrosion materials from the repair area, as necessary. Refer to [Anti-Corrosion Treatment and Repair](#).
7. Cut the panel (1 and 2) where sectioning is to be performed.

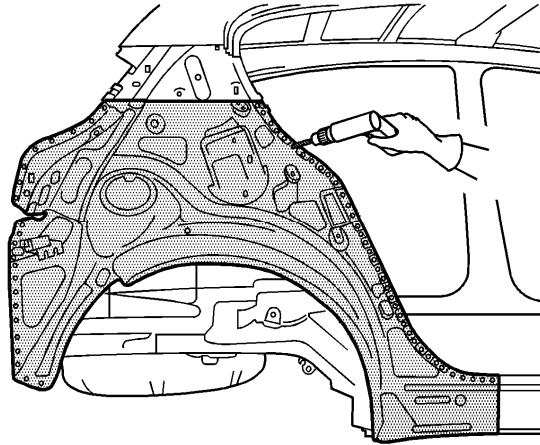

8. Locate and drill out all factory welds. Note the number and location of the welds for installation of the service part.
9. Remove the damaged quarter panel.

## [Installation Procedure](#)

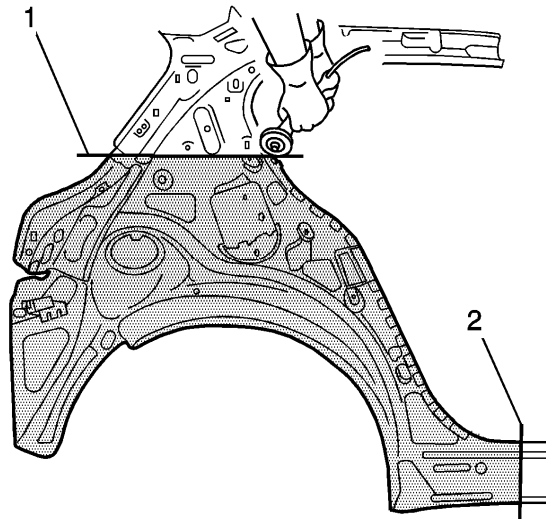

1. Cut the replacement quarter panel section at corresponding locations (1 and 2). The new panel must be cut 50 mm longer than the old part, to allow for an overlap sectioning repair.

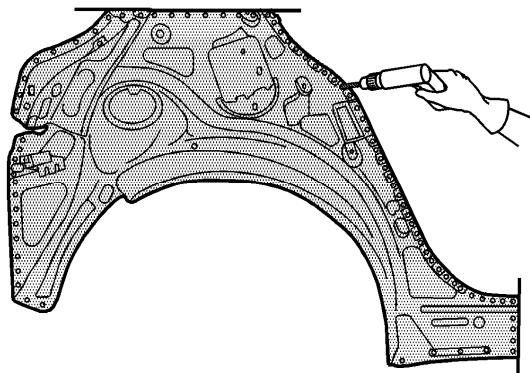

**Important:** In any area damaged beyond recognition, or if structural weld-thru adhesive is present, space the plug weld holes 40 mm (1½ in) apart.

2. Drill 8 mm (5/16 in) plug weld holes in the service part as necessary in the locations noted from the original panel and along the sectioning cut. Locate these holes 25 mm (1 in) from the edge.

3. Prepare all attachment surfaces as necessary.
4. Apply GM-Approved weld-thru coating or equivalent to all mating surfaces. Refer to [Anti-Corrosion Treatment and Repair](#) .
5. Position the quarter panel to the vehicle using 3-dimensional measuring equipment. Clamp in place.

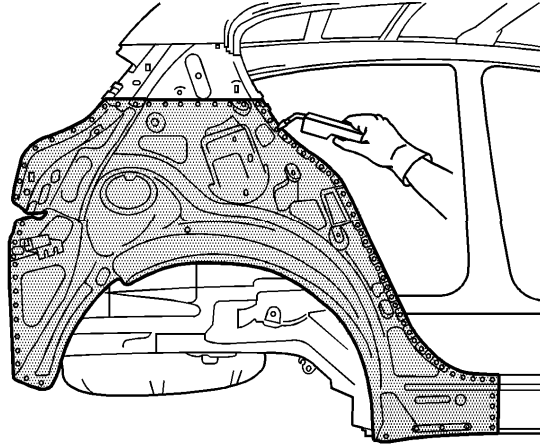

6. Plug weld accordingly.

**Important:** To create a solid weld with minimum heat distortion make 25 mm (1 in) stitch welds along the seam with 25 mm (1 in) gaps between them. Then go back and complete the stitch weld.

7. Stitch the weld sectioning joint.
  8. Clean and prepare all welded surfaces.
  9. Apply the sealers and anti-corrosion materials to the repair area, as necessary. Refer to [Anti-Corrosion Treatment and Repair](#) .
  10. Paint and repair the area. Refer to [Basecoat/Clearcoat Paint Systems](#) .
  11. Install all related panels and components.
  12. Connect the negative battery cable.
  13. Enable the SIR system.
-