

Body Lock Pillar Outer Panel Reinforcement Replacement (Sedan)

Removal Procedure

Caution: Refer to [Approved Equipment for Collision Repair Caution](#) in Cautions and Notices.

1. Disable the SIR system. Refer to [SIR Disabling and Enabling](#) .
2. Disconnect the negative battery cable. Refer to [Battery Negative Cable Disconnection and Connection](#) .
3. Remove all related panels and components.
4. Repair as much of the damaged area as possible. Refer to [Dimensions - Body](#) .
5. Remove the sealers and anti-corrosion materials from the repair area, as necessary. Refer to [Anti-Corrosion Treatment and Repair](#) .

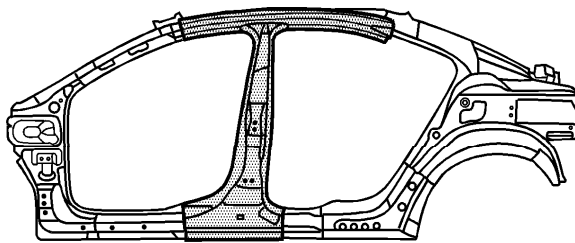

Important: Do not damage any inner panels or reinforcements.

Important: Note the number and location of the factory welds for installation of the center pillar reinforcement.

6. Locate and drill out all the necessary factory welds.

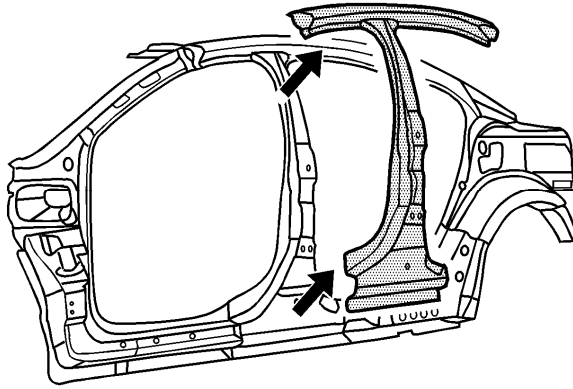

7. Remove the damaged front pillar.

Installation Procedure

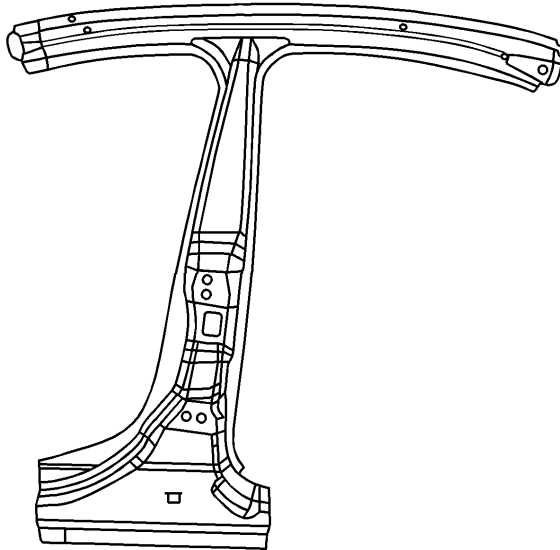

Important: If the location of the original plug weld holes can not be determined, space the plug weld holes every 40 mm (1½ in) apart.

1. Drill 8 mm (5/16 in) plug weld holes in the service reinforcement as necessary in the corresponding locations noted on the original panel.
2. Prepare all mating surfaces for welding as necessary.
3. Apply GM-approved Weld-Thru Coating or equivalent to all mating surfaces.
Refer to [Anti-Corrosion Treatment and Repair](#) .

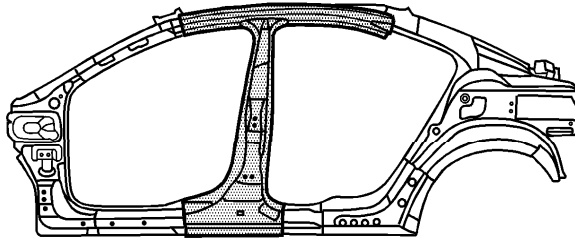

4. Position the service part on the vehicle using 3-dimensional measuring equipment.
Clamp the part in place.
5. Plug weld accordingly.
6. Clean and prepare all of the welded surfaces.
7. Apply the sealers and anti-corrosion materials to the repair area, as necessary.
Refer to [Anti-Corrosion Treatment and Repair](#) .
8. Paint the repaired area. Refer to [Basecoat/Clearcoat Paint Systems](#) .
9. Install all of the related panels and components.
10. Connect the negative battery cable. Refer to [Battery Negative Cable Disconnection and Connection](#) .
11. Enable the SIR system. Refer to [SIR Disabling and Enabling](#) .