

Rear Side Door Outer Panel Replacement

Removal Procedure

Caution: To avoid personal injury when exposed to welding flashes or to galvanized (Zinc Oxide) metal toxic fumes while grinding/cutting on any type of metal or sheet molded compound, you must work in a properly ventilated area, wearing an approved respirator, eye protection, earplugs, welding gloves, and protective clothing.

Important: Before beginning the repair, refer to [Metal Panel Bonding](#) for proper adhesive applicator preparations and general information.

1. Disconnect the negative battery cable. Refer to [Battery Negative Cable Disconnection and Connection](#).

Caution: Refer to [SIR Caution](#) in Cautions and Notices.

2. Disable the SIR system. Refer to [SIR Disabling and Enabling](#).
3. Remove the door from the vehicle. Refer to [Front Side Door Replacement](#) or to [Rear Side Door Replacement](#).

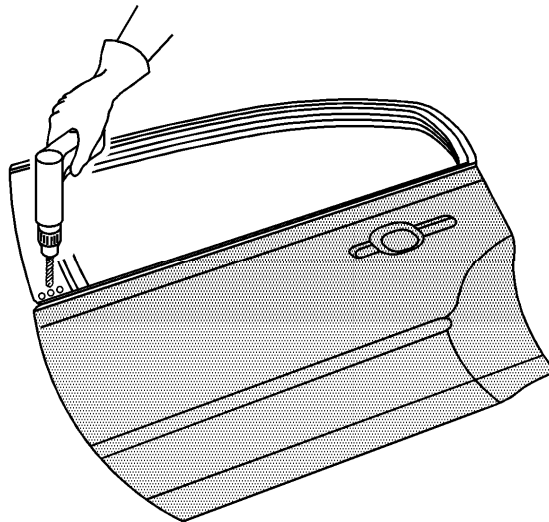

4. Locate and drill out all factory welds. Note the number and location of welds.

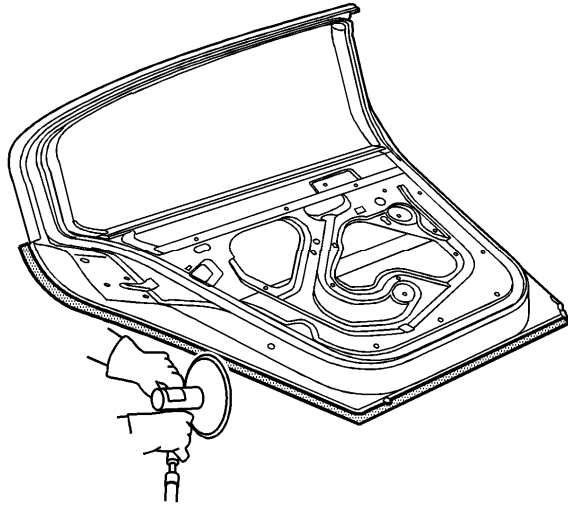

5. Grind the edges of the door outer panel to separate the outer door panel from the door shell.

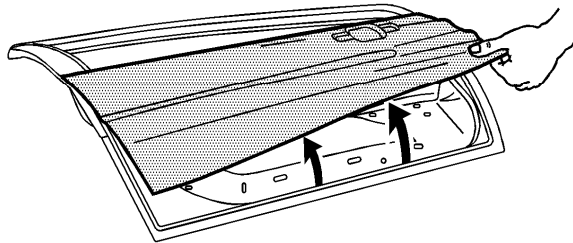

Caution: Inspection of the door guard beam for damage must be performed before replacement of the door outer panel. If damage to the door guard beam is found the door must be replaced. Failure to do so may compromise the structural integrity of the vehicle and may cause personal injury if the vehicle is involved in a collision.

6. Remove the outer door panel.

7. Remove the sealers and anti-corrosion materials from the repair area, as necessary. Refer to [Anti-Corrosion Treatment and Repair](#) .

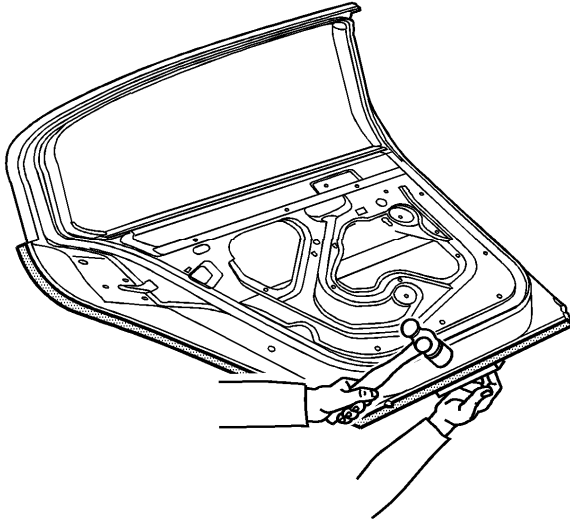

8. Straighten the edges of the door shell.

Installation Procedure

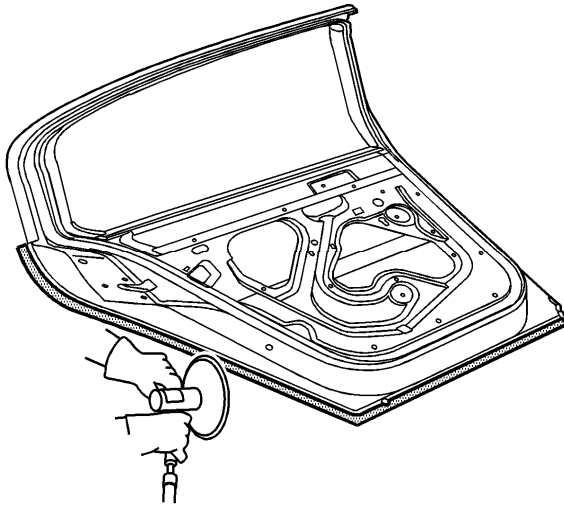

1. Using a grinding disk grind the surface of the door shell mating flanges to bare steel.

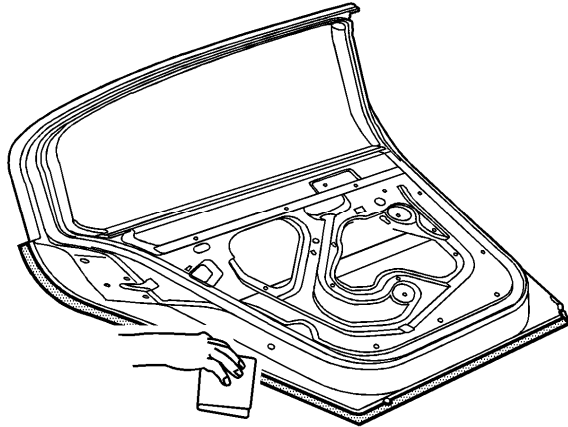

2. Scuff the opposing mating surfaces of the door outer panel to remove the gloss of the E-Coat.

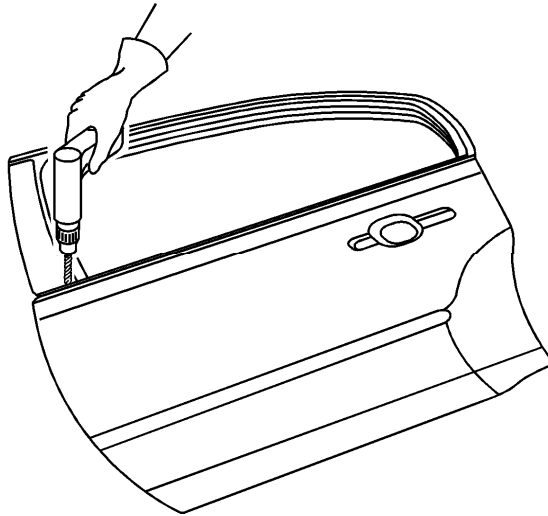

3. Drill 8 mm (5/16 in) plug weld holes as necessary in the locations noted from the original panel.

Important: If the location of the original plug welds can not be determined, space the plug weld holes every 40 mm (1 in) apart.

4. Clean the mating surfaces.

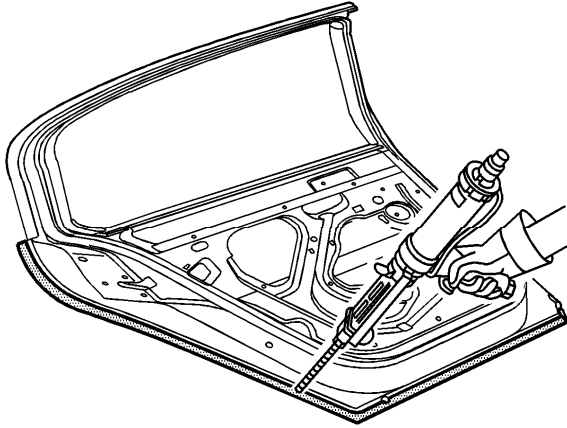

Important: The adhesive has a 40-50 minute working time. Do not allow the adhesive to totally cure off the vehicle, as proper alignment of the door outer panel to the door shell will be difficult.

5. Apply a 3-6 mm (1/8 to 1/4 in) bead of metal panel bonding adhesive to both of the mating surfaces.
6. Using a small acid brush, spread a coat of adhesive to cover all the bare metal surfaces to ensure corrosion protection.

Important: Do NOT pull the panels apart after joined together. Slide the panels against each other to realign the panels.

7. Apply a 9-13 mm (3/8-1/2 in) bead of metal panel bonding adhesive to the mating surface of the service panel.
8. Install the door outer panel to the door shell.

9. Clamp the door outer panel into position as required.

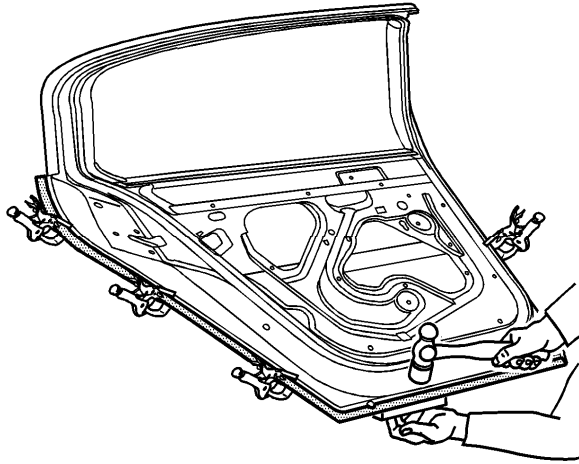

10. Using a hammer re-hem the hem flanges around the door shell .

Continue to hammer in stages along the hem flanges.

11. Using lacquer thinner remove the excess adhesive from the door panel area.
12. Install the door to the vehicle check the door outer panel for proper alignment, adjust the alignment as required.

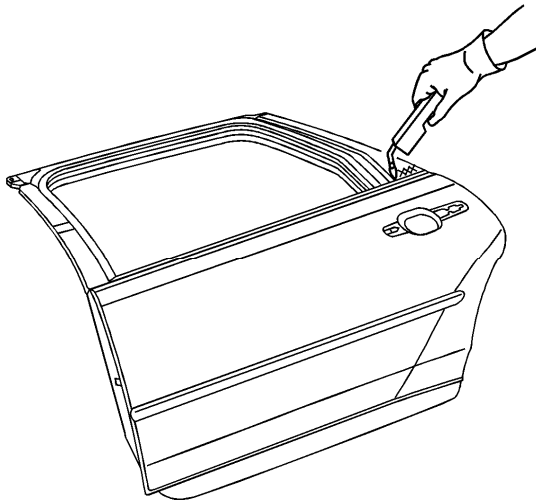

13. Metal-inert gas (MIG) weld the door outer panel to the door frame in the locations noted at the upper door frame.

14. Clean and prepare all welded surfaces.

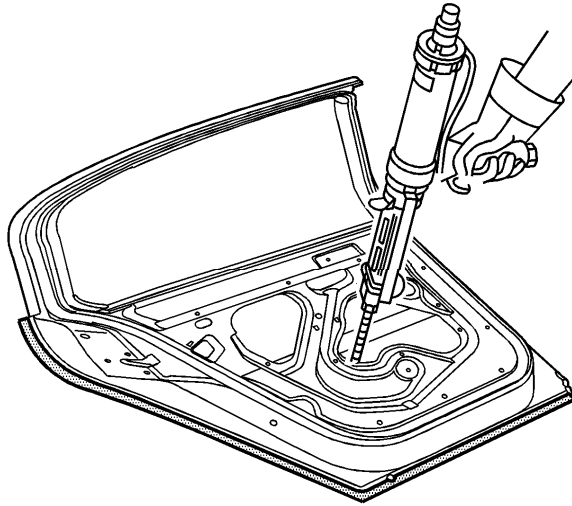

15. Apply Fusor super flexible anti-flutter foam-fast set, Fusor P/N 121/124 or equivalent in 4-5 evenly spaced locations between the door outer panel and the inner safety beam and the upper belt reinforcement.
16. Apply sealers and anti-corrosion materials to the repair area as necessary. Refer to [Anti-Corrosion Treatment and Repair](#) .
17. Paint the repaired area. Refer to [Basecoat/Clearcoat Paint Systems](#) .
18. Install all related panels and components.
19. Install the door to the vehicle. Refer to [Front Side Door Replacement](#) or to [Rear Side Door Replacement](#) .
20. Enable the SIR system. Refer to [SIR Disabling and Enabling](#) .
21. Connect the negative battery cable. Refer to [Battery Negative Cable Disconnection and Connection](#) .