

Windshield Frame Header Front Panel Replacement

Removal Procedure

Caution: Refer to [Approved Equipment for Collision Repair Caution](#) in Cautions and Notices.

1. Disable the SIR system. Refer to [SIR Disabling and Enabling](#) .
2. Disconnect the negative battery cable. Refer to [Battery Negative Cable Disconnection and Connection](#) .
3. Remove all related panels and components.
4. Repair as much of the damaged area as possible. Refer to [Dimensions - Body](#) .
5. Remove the sealers and anti-corrosion materials from the repair area, as necessary. Refer to [Anti-Corrosion Treatment and Repair](#) .

Important: Note the number and location of the factory welds for installation of the header panel.

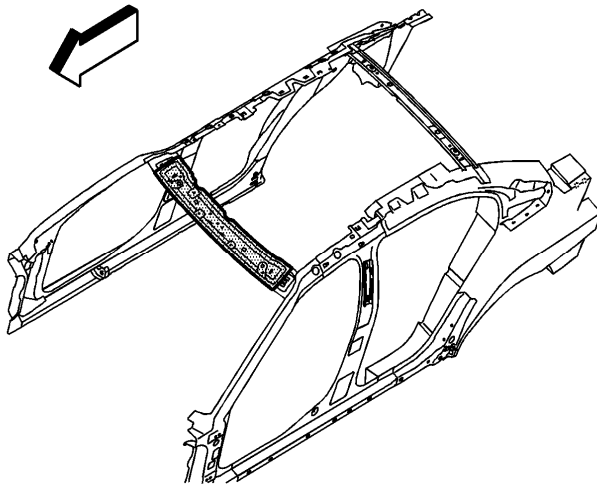

6. Locate and drill out all the necessary factory welds.

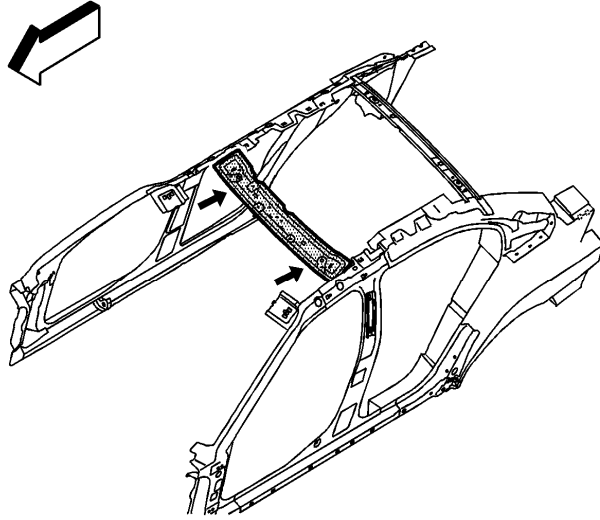

7. Remove the header panel.

Installation Procedure

Important: If the location of the original plug weld holes can not be determined, space the plug weld holes every 40 mm (1½ in) apart.

1. Drill 8 mm (5/16 in) plug weld holes in the service part as necessary in the locations noted from the original panel.
2. Prepare all mating surfaces as necessary.
3. Apply GM-approved Weld-Thru Coating or equivalent to all mating surfaces. Refer to [Anti-Corrosion Treatment and Repair](#) .

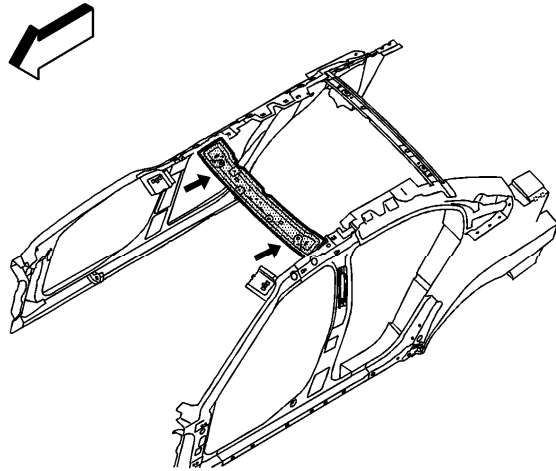

4. Position the header panel to the vehicle using 3-dimensional measuring equipment. Clamp the front header panel in place.

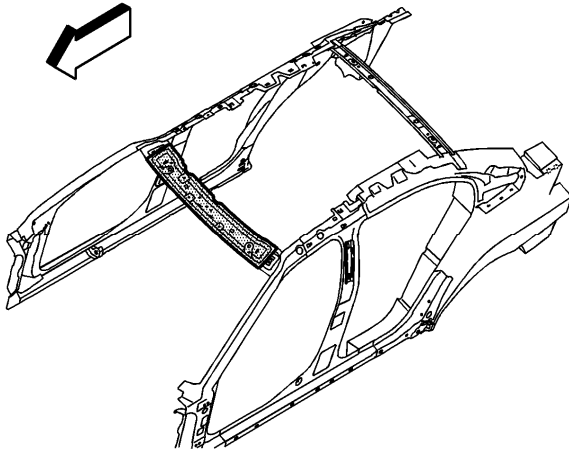

5. Plug weld accordingly.
6. Clean and prepare all of the welded surfaces.
7. Install all of the related panels and components.
8. Apply the sealers and anti-corrosion materials to the repair area, as necessary. Refer to [Anti-Corrosion Treatment and Repair](#) .
9. Paint the repaired area. Refer to [Basecoat/Clearcoat Paint Systems](#) .
10. Connect the negative battery cable. Refer to [Battery Negative Cable Disconnection and Connection](#) .
11. Enable the SIR system. Refer to [SIR Disabling and Enabling](#) .