

874221

Hinge Pillar Body Sectioning - Front

Removal Procedure

Caution: To avoid personal injury when exposed to welding flashes or to galvanized (Zinc Oxide) metal toxic fumes while grinding/cutting on any type of metal or sheet molded compound, you must work in a properly ventilated area, wearing an approved respirator, eye protection, earplugs, welding gloves, and protective clothing.

Caution: Sectioning should be performed only in the recommended areas. Failure to do so may compromise the structural integrity of the vehicle and cause personal injury if the vehicle is in a collision.

The sedan body side outer panel is available either in one piece or in front or rear portions. The front and the rear halves are cut about half way across the rear door opening. You can perform any one of these replacement procedures separately or in any combination, depending upon the extent of damage to the vehicle. Sectioning must take place in specified areas only. Stay away from the door and window opening radius areas. Section only in straight areas of the openings.

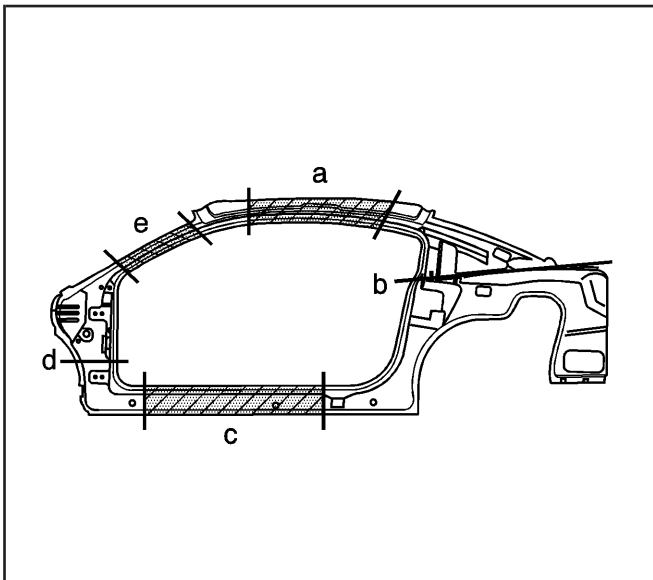

874304

The coupe body side outer panel is available as a one-piece panel only. You can perform any one of these replacement procedures separately or in any combination, depending upon the extent of the damage to the vehicle. Sectioning must take place in specified areas only. Stay away from the door and window opening radius areas. Section only in straight areas of the openings.

Caution: When performing service on or near the SIR components or the SIR wiring, the SIR system must be disabled. Refer to SIR Disabling and Enabling Zones. Failure to observe the correct procedure could cause deployment of the SIR components, personal injury, or unnecessary SIR system repairs.

1. Disable the SIR system.

Caution: Before servicing any electrical component, the ignition key must be in the OFF or LOCK position and all electrical loads must be OFF, unless instructed otherwise in these procedures. If a tool or equipment could easily come in contact with a live exposed electrical terminal, also disconnect the negative battery cable. Failure to follow these precautions may cause personal injury and/or damage to the vehicle or its components.

2. Disconnect the negative battery cable.
3. Remove all related panels and components.
4. Repair as much of the damaged area as possible. Refer to *Dimensions - Body* on page 3-7.
5. Remove the sealers and anti-corrosion materials from the repair area, as necessary.

Important: Sectioning can be done anywhere in the straight areas of the windshield pillar and along the rocker panel.

6. Locate the area on the panel where sectioning will be performed.
7. Measure from any trim attachment hole within the recommended sectioning areas. Mark the location for section cutting on the vehicle at the windshield pillar and rocker panel locations.

Important: Note the number and location of the factory welds for installation of the hinge pillar.

8. Locate and drill out all factory welds.

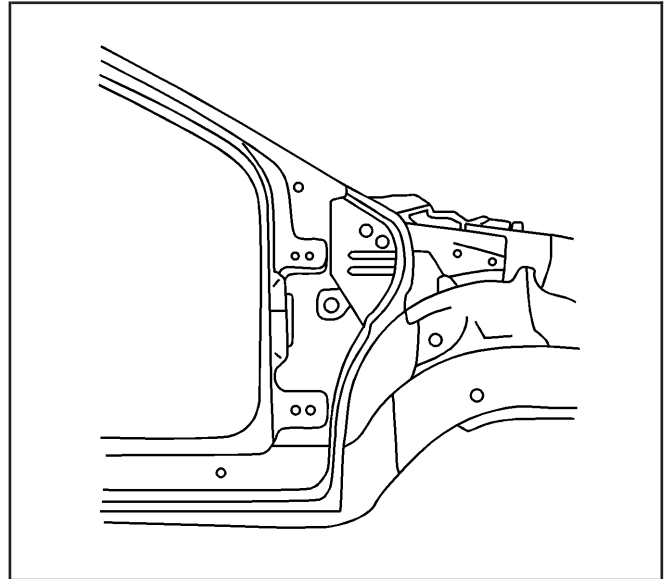

876963

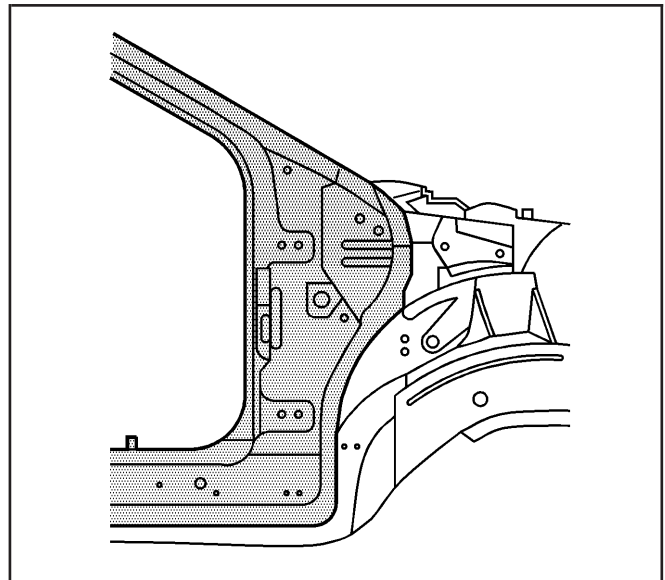

876965

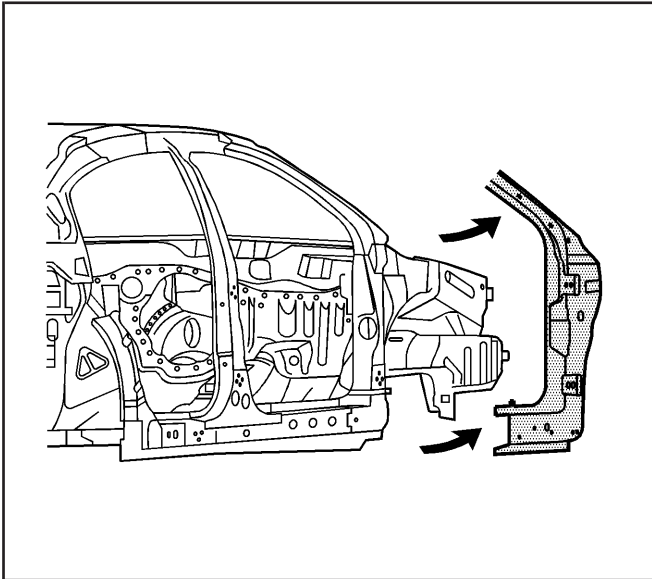

876966

Important: Do NOT damage any other panels or reinforcements when cutting at the marked locations.

9. Cut the panel at the location laid out in the previous steps.
10. Remove the damaged hinge pillar.

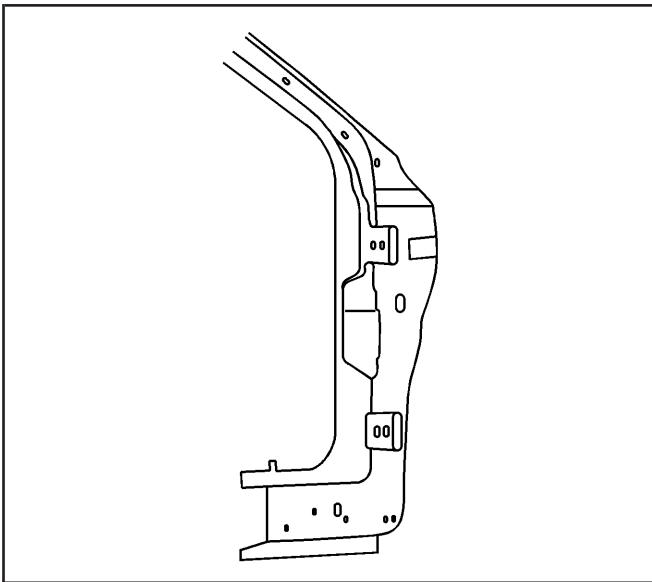

876964

Installation Procedure

1. Locate the area on the service panel where you will perform sectioning.
2. Measure and mark the cut line location on the service part at the same location as on the vehicle layout.
3. Cut the outer front hinge pillar in corresponding locations to fit the remaining original panel. The sectioning joint should be trimmed to allow a gap of 1½ times the metal thickness at the sectioning joint.

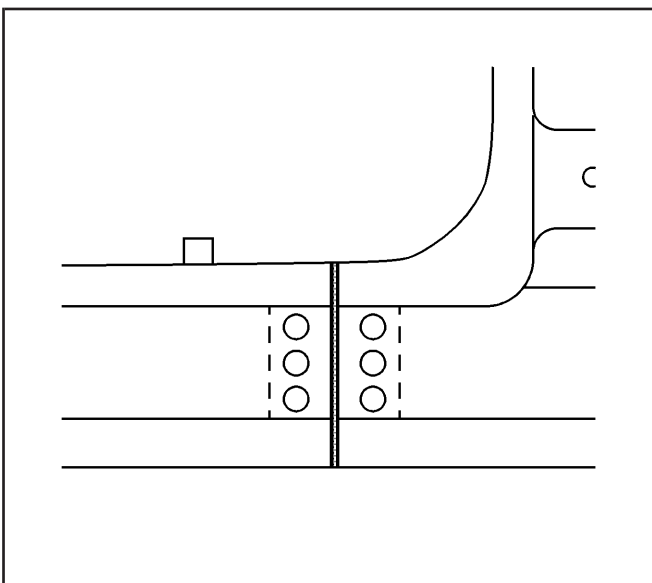

876967

4. Create a 50 mm (2 in) backing plate from the unused portion of the service part for the windshield area.
5. Create a 100 mm (4 in) backing plate from the unused portion of the service part for the rocker area.
6. Trim the backing plates as necessary to fit behind the panel at the sectioning joint.

Important: If the location of the original plug weld holes can not be determined, space the plug weld holes every 40 mm (1 1/2 in) apart.

7. Drill 8 mm (5/16 in) plug weld holes along the sectioning area in the service part, and at the locations noted from the original panel.

8. Prepare all mating surfaces as necessary.
9. Apply 3M Weld-Thru Coating P/N 05916 or equivalent to all mating surfaces.
10. Fit the backing plates halfway into the sectioning joints, 25 mm (1 in) at the windshield pillar and 50 mm (2 in) at the rocker panel areas. Clamp the plates in place, and plug weld to the section joint
11. Position the outer front pillar to the vehicle using 3-dimensional measuring equipment. Clamp the pillar in place.
12. Plug weld accordingly.

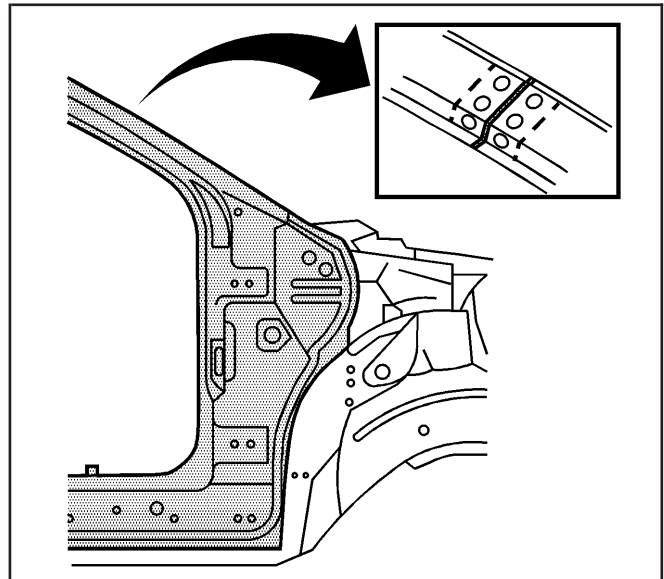

876968

13. Plug weld accordingly.
14. Stitch weld the butt weld locations.
15. To create a solid weld with minimum heat distortion, make a 25 mm (1 in) stitch weld along the seam with gaps of 25 mm (1 in). Go back and complete the stitch weld.
16. Clean and prepare all of the welded surfaces.
17. Apply the sealers and anti-corrosion materials to the repair area, as necessary.
18. Paint the repaired area.
19. Install all of the related panels and components.
20. Connect the negative battery cable.
21. Enable the SIR system.

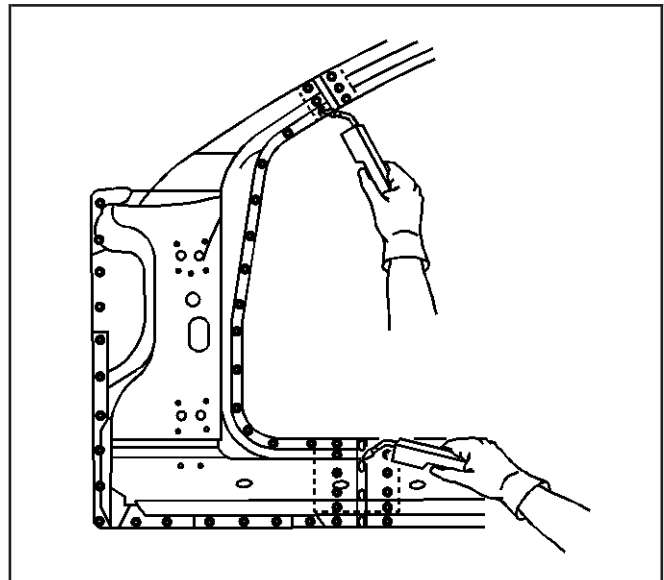

787665

Roof Panel Replacement - Outer

Removal Procedure

Caution: To avoid personal injury when exposed to welding flashes or to galvanized (Zinc Oxide) metal toxic fumes while grinding/cutting on any type of metal or sheet molded compound, you must work in a properly ventilated area, wearing an approved respirator, eye protection, earplugs, welding gloves, and protective clothing.

Caution: Refer to SIR Caution on page 1-1 in General Information.

1. Disable the SIR system.

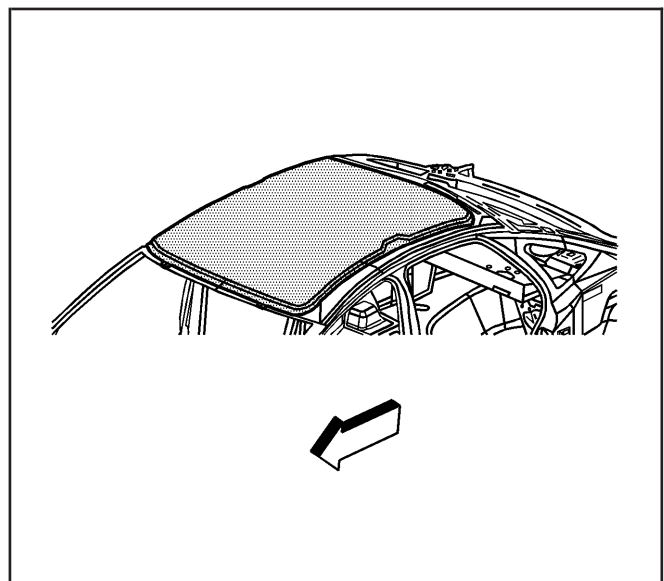

870880