

Pillar Lock Front Door Sectioning - Outer

Removal Procedure

Caution: To avoid personal injury when exposed to welding flashes or to galvanized (Zinc Oxide) metal toxic fumes while grinding/cutting on any type of metal or sheet molded compound, you must work in a properly ventilated area, wearing an approved respirator, eye protection, earplugs, welding gloves, and protective clothing.

Caution: Sectioning should be performed only in the recommended areas. Failure to do so may compromise the structural integrity of the vehicle and cause personal injury if the vehicle is in a collision.

1. The body side outer panel is available either in one piece or in front or rear portions. The front and the rear halves are cut about half way across the rear door opening. You can perform any one of these replacement procedures separately or in any combination, depending upon the extent of the damage to the vehicle. Sectioning must take place in specified areas only.

Remove all related panels and components.

Caution: When performing service on or near the SIR components or the SIR wiring, the SIR system must be disabled. Refer to SIR Disabling and Enabling Zones. Failure to observe the correct procedure could cause deployment of the SIR components, personal injury, or unnecessary SIR system repairs.

2. Disable the SIR system.

Caution: Before servicing any electrical component, the ignition key must be in the OFF or LOCK position and all electrical loads must be OFF, unless instructed otherwise in these procedures. If a tool or equipment could easily come in contact with a live exposed electrical terminal, also disconnect the negative battery cable. Failure to follow these precautions may cause personal injury and/or damage to the vehicle or its components.

3. Disconnect the negative battery cable.
4. Remove the sealers and anti-corrosion materials from the repair area, as necessary and note their location.
5. Repair as much of the damaged area as possible. Refer to *Dimensions - Body* on page 3-7.

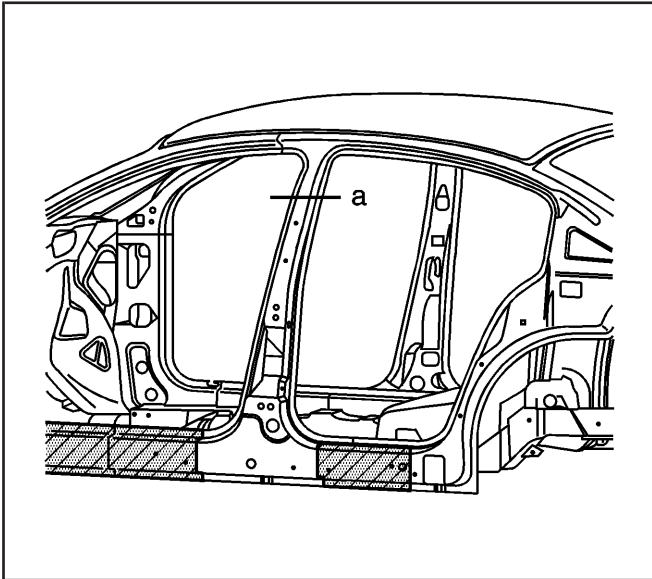

874225

6. At the top of the center pillar, mark a line (a) through the center of the second outer trim attachment hole.

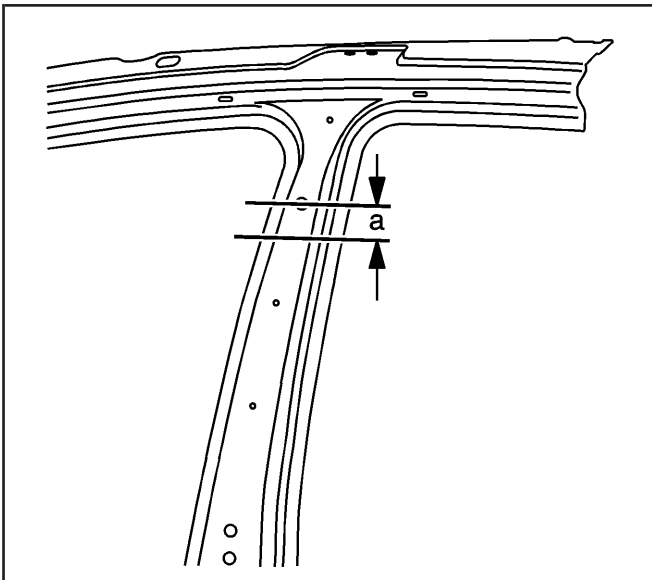

875628

7. Measure down 50 mm (2 in) from the mark created in the previous step.

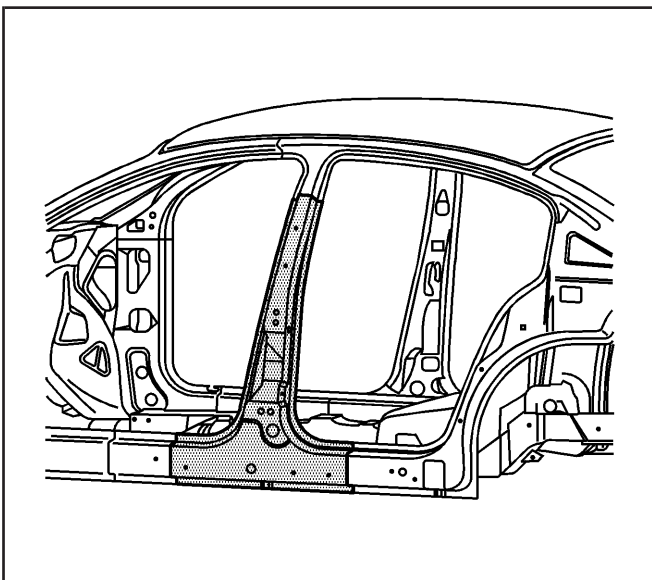

876971

Important: Sectioning procedures can only take place in the straight areas of the body side panel.

8. Measure from any key feature in the panel. Lay out the cut line location on the body side panel.
9. Create cut lines on the rocker panel within the approved sectioning locations as needed.
10. Cut the panel at the center pillar where the lay out line was previously formed.

- Cut the panel at the rocker panel area where sectioning is to be performed, within the straight sections only.

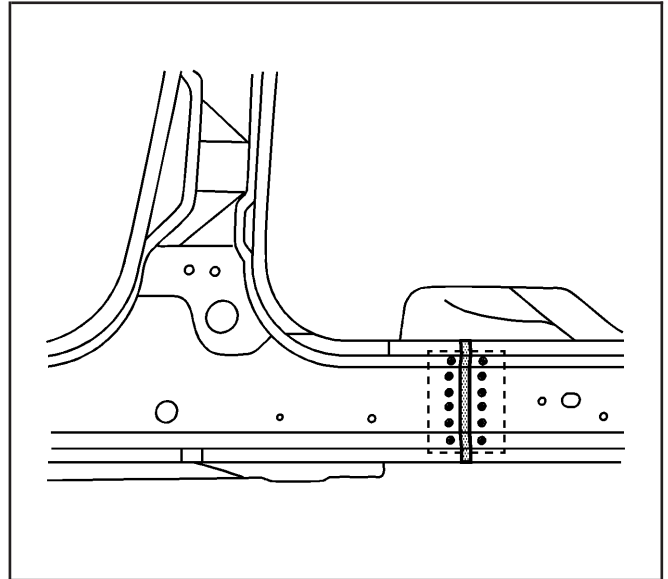

876974

- Locate and drill out all factory welds. Note the number and location of welds for installation of the service part.
- Remove the damaged center pillar.

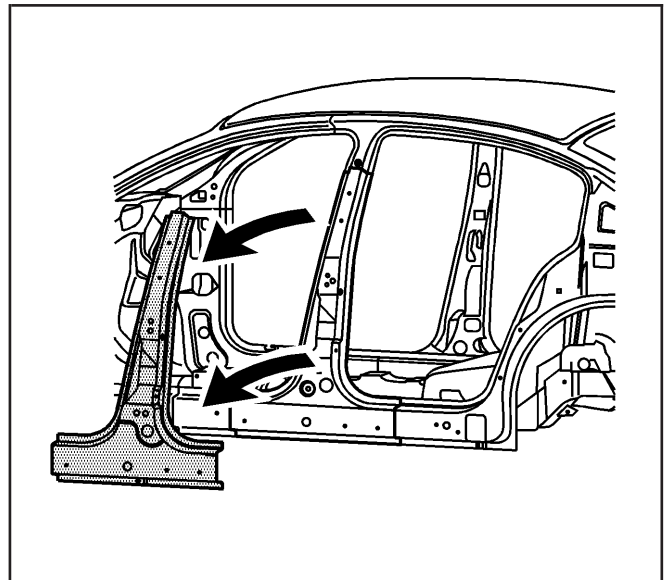

876972

Installation Procedure

- Cut the outer center pillar in corresponding locations to fit the remaining original panel. The sectioning joint should be trimmed to allow a gap of $1\frac{1}{2}$ times the metal thickness at the sectioning joint.
- In all the rocker panel areas, create a 100 mm (4 in) backing plate from the unused portion of the service part. Trim the backing plates as necessary to fit behind the sectioning joint.
- In the upper center pillar area, cut a 50 mm (4 in) backing plate from the unused portion of the source part trim as necessary.

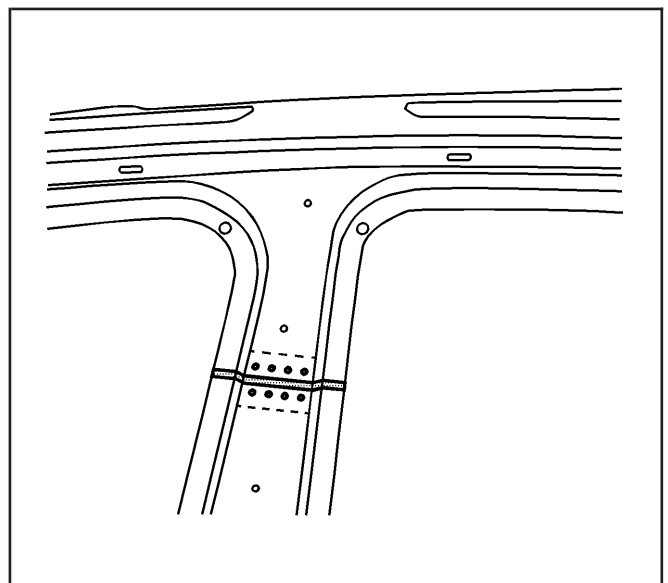

876973

Important: If the location of the original plug weld holes can not be determined, space the plug weld holes every 40 mm (1½ in) apart.

4. Drill 8 mm (5/16 in) along the sectioning cuts on the remaining original part. Locate these holes 13 mm (½ in) from the edge of the part and spaced 40 mm (1½ in) apart.
5. Drill 8 mm (5/16-in) plug weld holes in the service part as necessary in the corresponding locations noted on the original panel.
6. Prepare all mating surfaces for welding as necessary.
7. Apply 3M Weld-Thru Coating P/N 05916 or equivalent to all mating surfaces.
8. Fit the backing plates into the sectioning joints for the following distances:
 - 50 mm (2 in) for the rocker section
 - 25 mm (1 in) for the center pillar section
9. Clamp the backing plates in place. Plug weld the backing plates to the vehicle.
10. Position the outer center pillar to the vehicle using 3-dimensional measuring equipment. Clamp the pillar in place.
11. Plug weld accordingly.
12. To create a solid weld with minimum heat distortion, make a 25 mm (1 in) stitch weld along the seam with gaps of 25 mm (1 in). Go back and complete the stitch weld.
13. Clean and prepare all of the welded surfaces.
14. Apply sound deadening materials as necessary.
15. Apply the sealers and anti-corrosion materials to the repair area, as necessary.
16. Paint the repaired area.
17. Install all of the related panels and components.
18. Connect the negative battery cable.
19. Enable the SIR system.

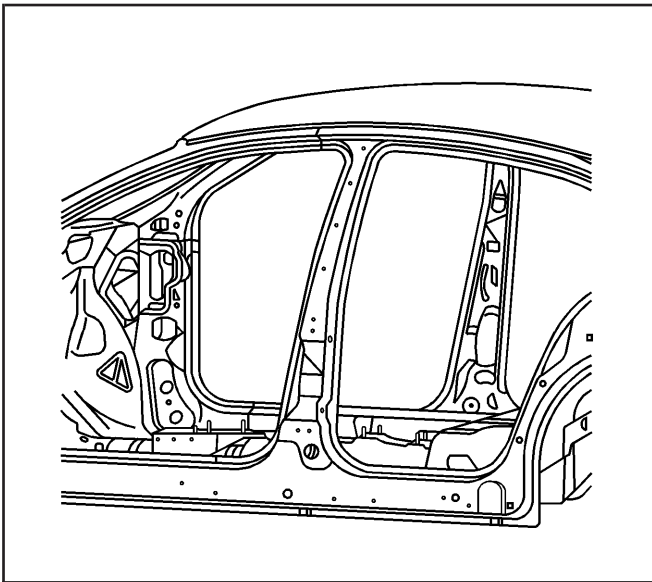

876969