

Pillar Lock Front Door Reinforcement Replacement - Outer

Removal Procedure

Caution: To avoid personal injury when exposed to welding flashes or to galvanized (Zinc Oxide) metal toxic fumes while grinding/cutting on any type of metal or sheet molded compound, you must work in a properly ventilated area, wearing an approved respirator, eye protection, earplugs, welding gloves, and protective clothing.

Caution: When performing service on or near the SIR components or the SIR wiring, the SIR system must be disabled. Refer to SIR Disabling and Enabling Zones. Failure to observe the correct procedure could cause deployment of the SIR components, personal injury, or unnecessary SIR system repairs.

1. Disable the SIR system.

Caution: Before servicing any electrical component, the ignition key must be in the OFF or LOCK position and all electrical loads must be OFF, unless instructed otherwise in these procedures. If a tool or equipment could easily come in contact with a live exposed electrical terminal, also disconnect the negative battery cable. Failure to follow these precautions may cause personal injury and/or damage to the vehicle or its components.

2. Disconnect the negative battery cable.
3. Remove all related panels and components.
4. Repair as much of the damaged area as possible. Refer to *Dimensions - Body* on page 3-7.
5. Remove the sealers and anti-corrosion materials from the repair area, as necessary.

Important: Do not damage any inner panels or reinforcements.

Important: Note the number and location of the factory welds for installation of the center pillar reinforcement.

6. Locate and drill out all the necessary factory welds.

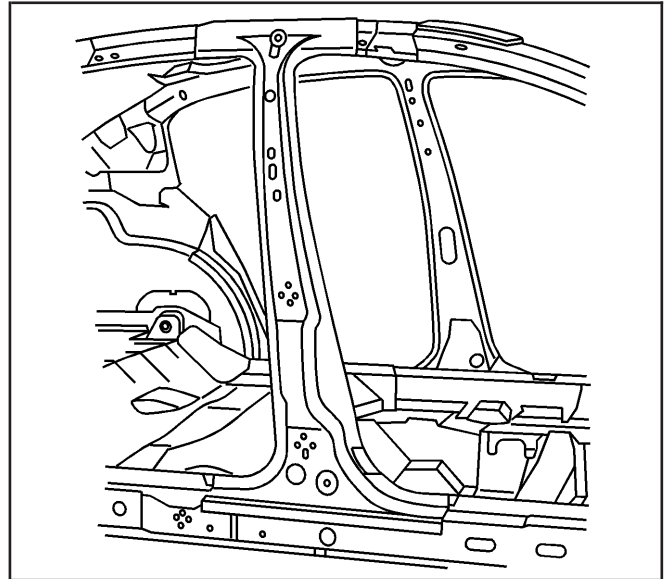

870941

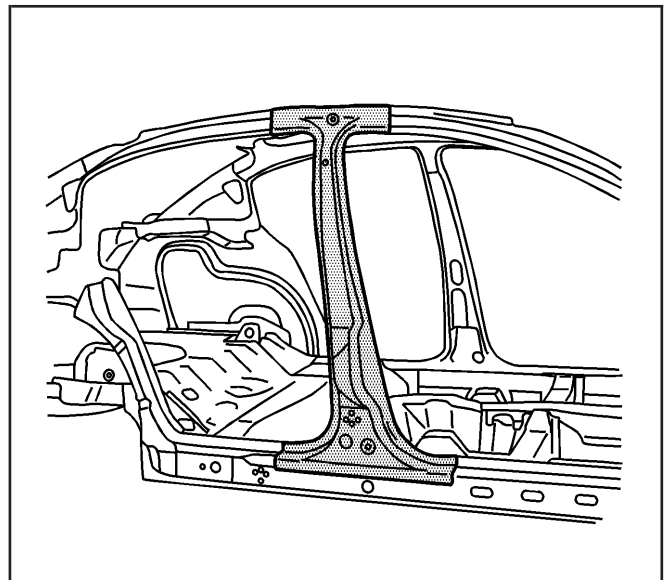

870945

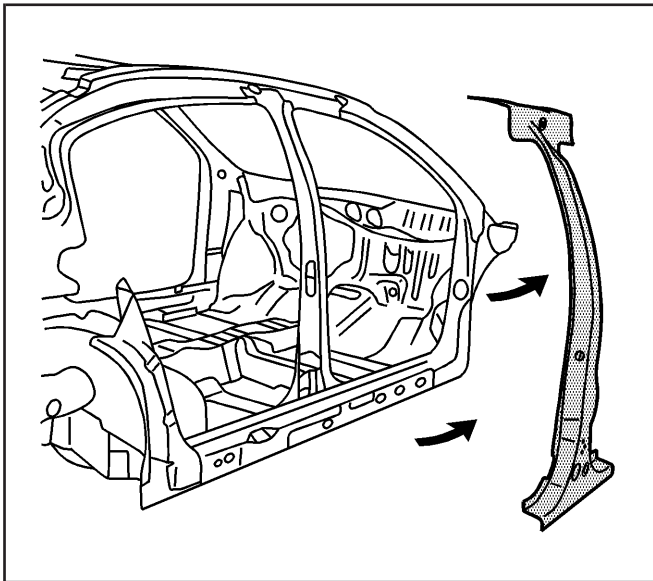

870947

- Remove the damaged front pillar.

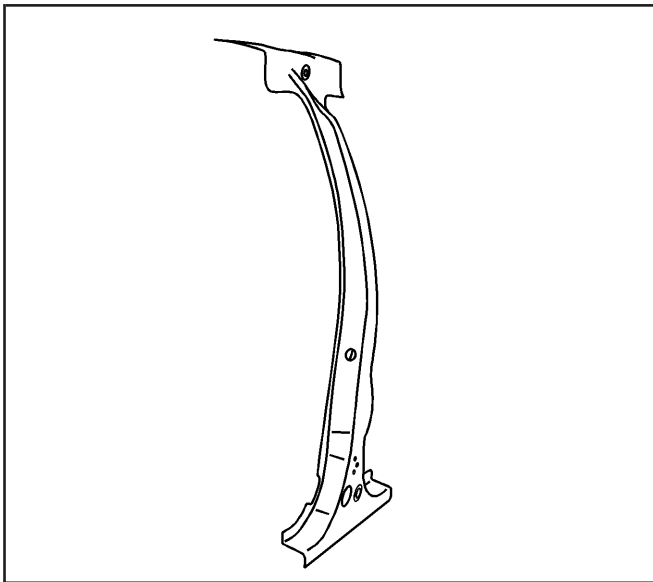

870943

Installation Procedure

Important: If the location of the original plug weld holes can not be determined, space the plug weld holes every 40 mm (1½ in) apart.

- Drill 8 mm (5/16 in) plug weld holes in the service reinforcement as necessary in the corresponding locations noted on the original panel.
- Prepare all mating surfaces for welding as necessary.
- Apply 3M® Weld-Thru Coating P/N 05916 or equivalent to all mating surfaces.

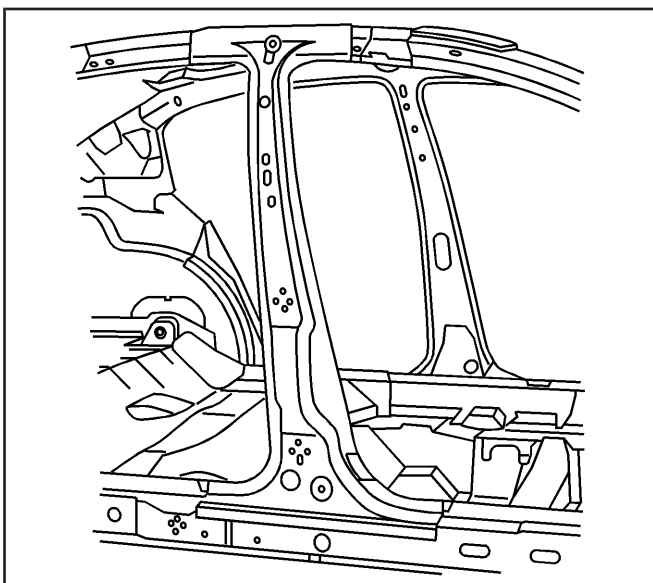

870941

- Position the service part on the vehicle using 3-dimensional measuring equipment. Clamp the part in place.
- Plug weld accordingly.
- Clean and prepare all of the welded surfaces.
- Apply the sealers and anti-corrosion materials to the repair area, as necessary.
- Paint the repaired area.
- Install all of the related panels and components.
- Connect the negative battery cable.
- Enable the SIR system.