

14. Tack weld the part into position.
15. Inspect the service rear rail for proper dimensions, using 3-dimensional measuring equipment.
16. Plug weld at each 8 mm plug weld hole location.
17. Stitch weld along the entire sectioning joint. Make welds along the seam with 25 mm (1 in) gaps between. Weld the gaps.
18. Clean and prepare the welded surfaces.
19. Install all of the related panels and components.
20. Apply the sealers and anti-corrosion materials to the repair area, as necessary.
21. Paint the repaired area.
22. Enable the SIR system.
23. Connect the negative battery cable.

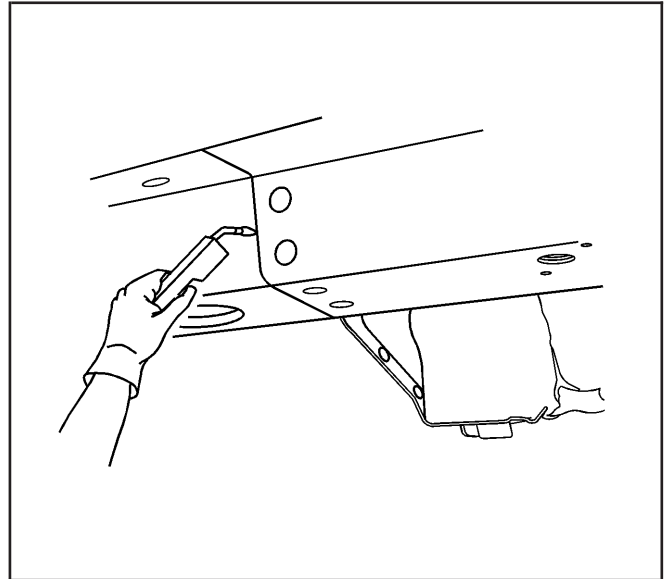

876961

Rail Underbody Gusset Replacement - Rear

Removal Procedure

Caution: To avoid personal injury when exposed to welding flashes or to galvanized (Zinc Oxide) metal toxic fumes while grinding/cutting on any type of metal or sheet molded compound, you must work in a properly ventilated area, wearing an approved respirator, eye protection, earplugs, welding gloves, and protective clothing.

Caution: When performing service on or near the SIR components or the SIR wiring, the SIR system must be disabled. Refer to SIR Disabling and Enabling Zones. Failure to observe the correct procedure could cause deployment of the SIR components, personal injury, or unnecessary SIR system repairs.

1. Disable the SIR system.

Caution: Before servicing any electrical component, the ignition key must be in the OFF or LOCK position and all electrical loads must be OFF, unless instructed otherwise in these procedures. If a tool or equipment could easily come in contact with a live exposed electrical terminal, also disconnect the negative battery cable. Failure to follow these precautions may cause personal injury and/or damage to the vehicle or its components.

2. Disconnect the negative battery cable.
3. Remove all related panels and components.
4. Repair as much of the damage as possible. Refer to *Dimensions - Body* on page 3-7.
5. Remove the sealers and anti-corrosion materials from the repair area, as necessary.

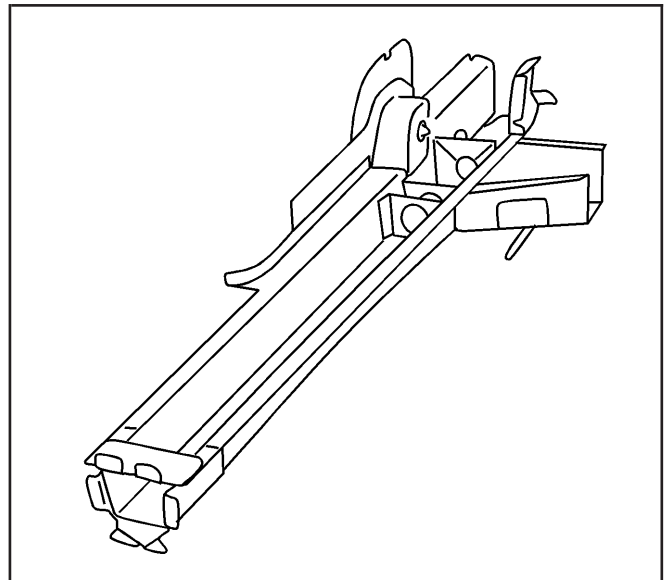

874146

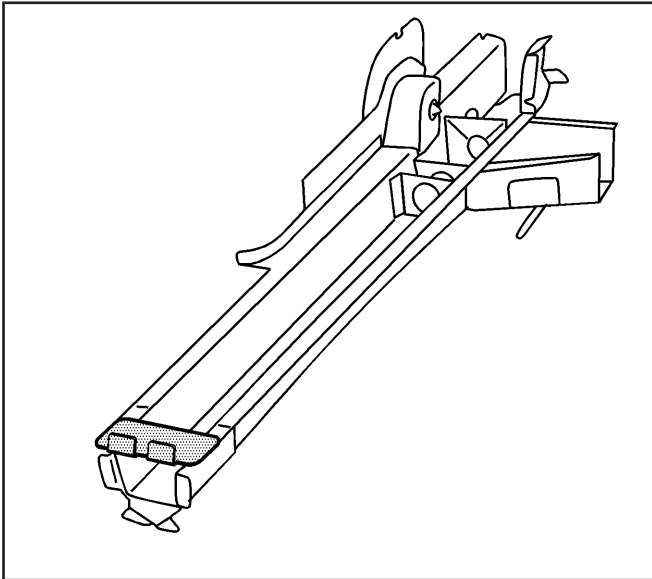

874152

Important: Note the number and location of the factory welds for installation of the underbody gusset to the rear rail.

6. Locate and drill out all the necessary factory welds.

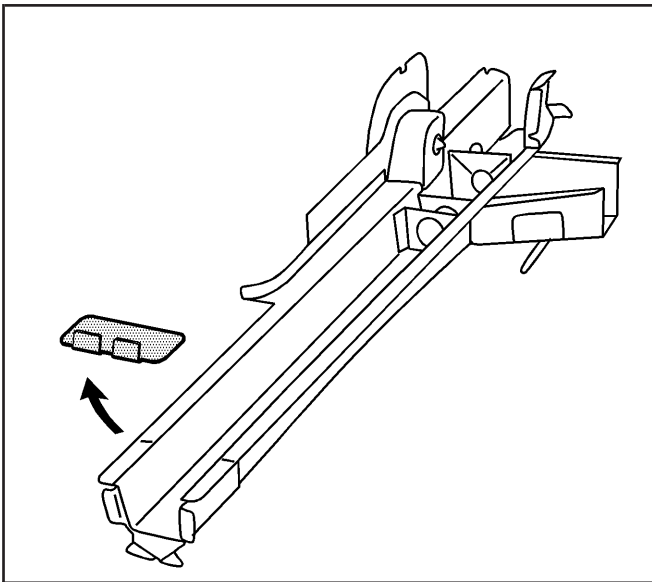

874156

7. Remove the underbody gusset from the rear rail.

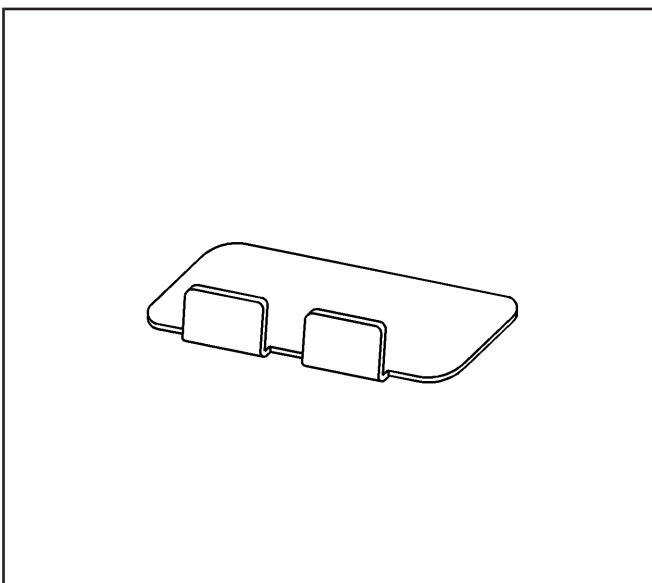

874149

Installation Procedure

Important: If the location of the original plug weld holes can not be determined, space the plug weld holes every 40 mm (1½ in) apart.

1. Drill 8 mm (5/16 in) plug weld holes in the service part as necessary in the corresponding locations noted on the original panel.
2. Prepare all mating surfaces as necessary.
3. Apply 3M® Weld-Thru coating P/N 05916 or equivalent to all mating surfaces.

4. Position the underbody gusset to the rear rail.

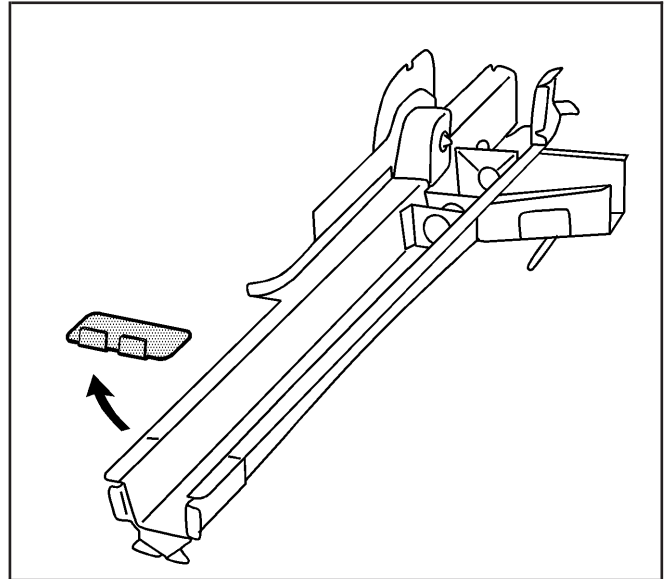

874156

5. Plug weld accordingly.
6. Clean and prepare all of the welded surfaces.
7. Install all of the related panels and components.
8. Apply the sealers and anti-corrosion materials to the repair area, as necessary.
9. Paint the repaired area.
10. Connect the negative battery cable.
11. Enable the SIR system.

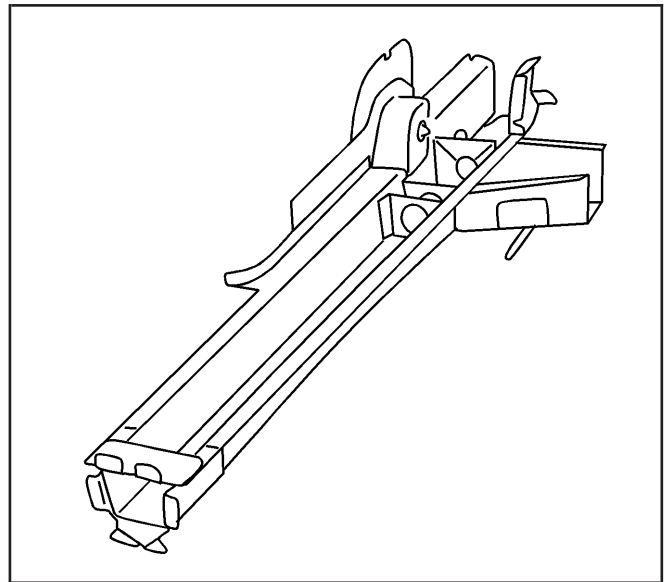

874146

Rail Underbody Reinforcement Replacement - Rear

Removal Procedure

Caution: To avoid personal injury when exposed to welding flashes or to galvanized (Zinc Oxide) metal toxic fumes while grinding/cutting on any type of metal or sheet molded compound, you must work in a properly ventilated area, wearing an approved respirator, eye protection, earplugs, welding gloves, and protective clothing.

Caution: Refer to SIR Caution on page 1-1 in General Information.

1. Disable the SIR system.

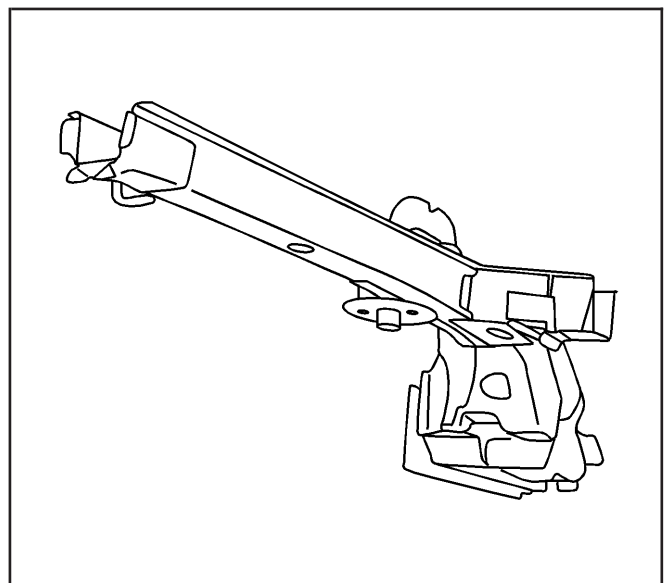

874158