

Rear Floor Panel Replacement

Removal Procedure

Important: The rear floor panel's front edge is layered between 2 sheet metal panels. To avoid unnecessary repairs, a portion of the original floor panel will be left welded in the vehicle. Please review complete repair procedure for further information

Caution: Refer to Approved Equipment for Collision Repair Caution in the Preface section.

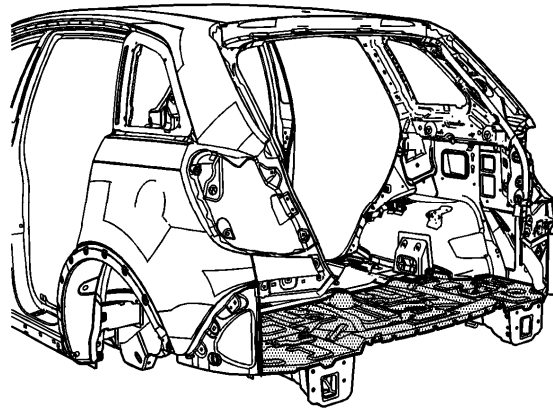

1. Disable the supplemental inflatable restraint (SIR) system. Refer to [SIR Disabling and Enabling](#).
2. Disconnect the negative battery cable. Refer to [Battery Negative Cable Disconnection and Connection](#).
3. Remove all related panels and components.

4. Repair as much of the damage as possible to factory specifications. Refer to [Dimensions - Body](#).
5. Note the location and remove the sealers and anti-corrosion materials from the repair area, as necessary. Refer to [Anti-Corrosion Treatment and Repair](#).

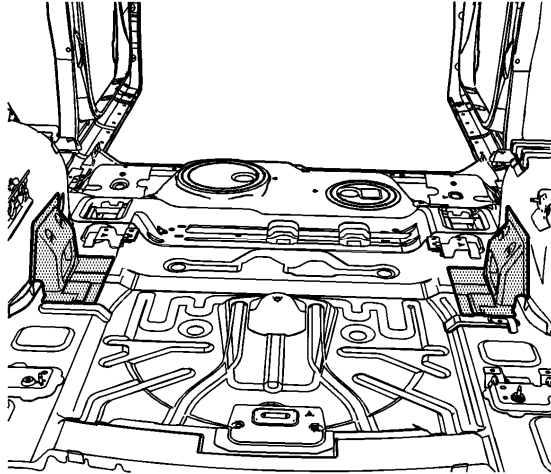

Important: Do not damage any inner panels or reinforcements.

6. Drill out the spot welds and remove the wheelhouse reinforcements.

Important: Do not drill out welds along the front edge of the panel seam.

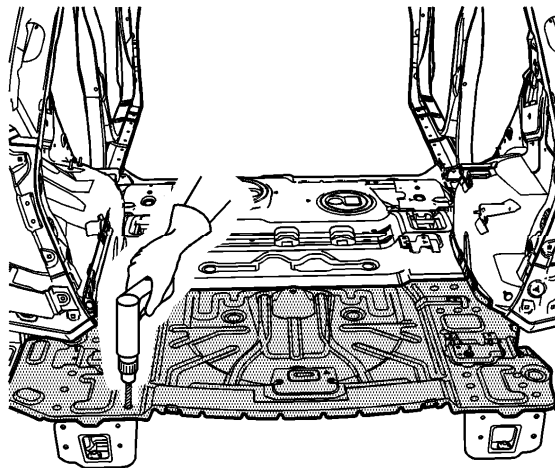

7. Locate and drill out all factory welds. Note the number and location of the welds for installation of the rear floor panel.

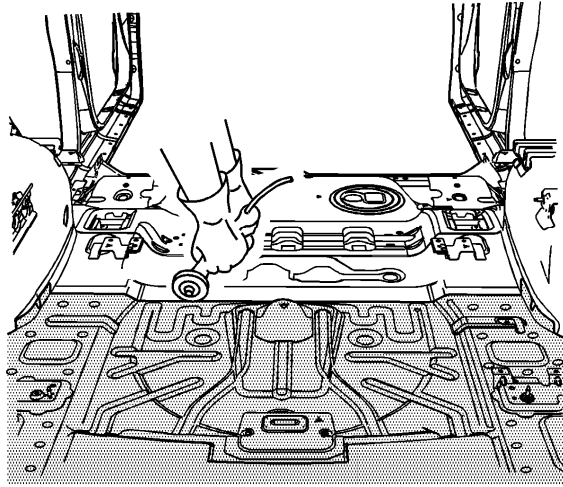

8. Cut floor panel along front edge of the panel seam.

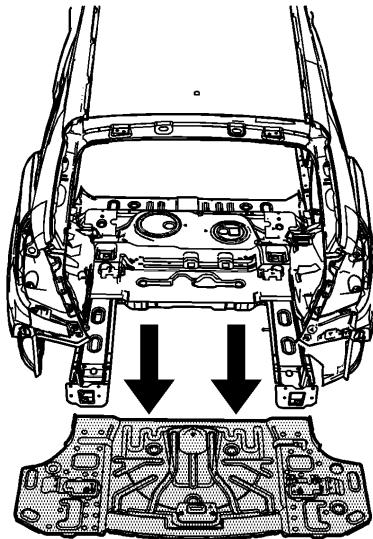

9. Remove the damaged rear floor panel.

[Installation Procedure](#)

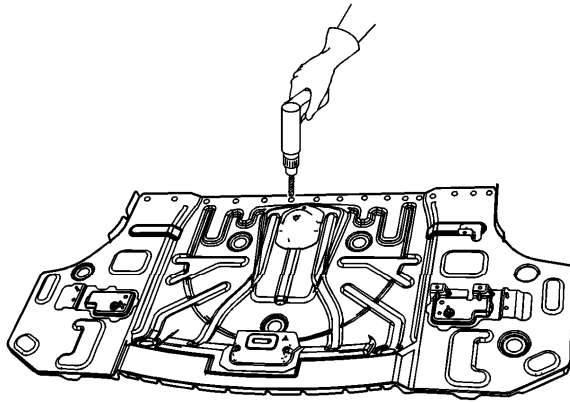

Important: If the location of the original plug weld holes can not be determined, space the plug weld holes every 40 mm (1 ½ in) apart.

Some panels may have structural weld-thru adhesive. It is necessary to replace the weld-thru adhesive with an additional spot weld between each factory spot weld.

1. Drill 8 mm (5/16 in) plug weld holes in the service part as necessary in the locations noted from the original panel.
2. Prepare all mating surfaces as necessary.
3. Apply GM approved weld-thru coating or equivalent to all mating surfaces. Refer to [Anti-Corrosion Treatment and Repair](#) .

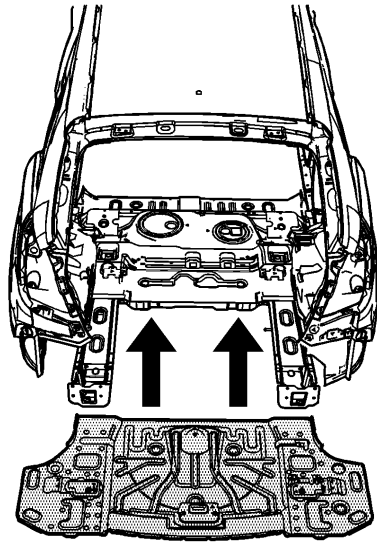

4. Position the rear floor panel to the vehicle.

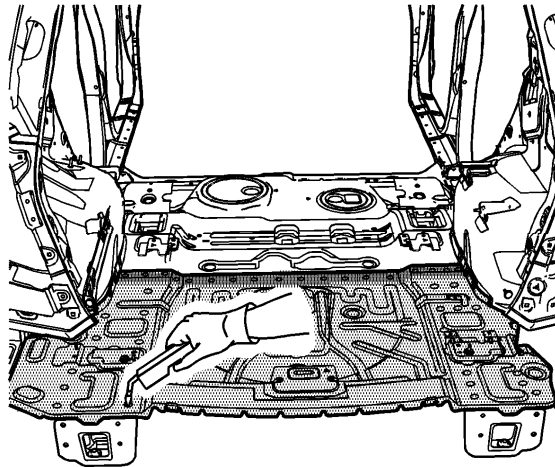

5. Overlap the front edge of the service floor panel on top of the existing front floor by approximately 30 mm until panel fits into place. Clamp the floor panel in place.

6. Plug weld accordingly.

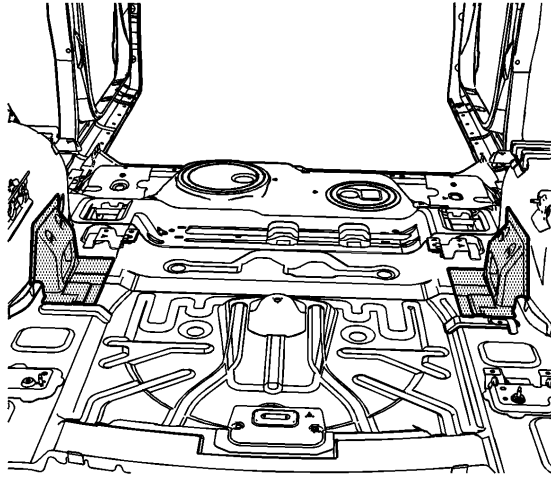

7. Position and weld wheelhouse reinforcement in place.
8. Clean and prepare all welded surfaces.
9. Apply the sealers and anti-corrosion materials to the repair area, as necessary.
Refer to [Anti-Corrosion Treatment and Repair](#).
10. Paint the repair area. Refer to [Basecoat/Clearcoat Paint Systems](#).
11. Install all related panels and components.
12. Connect the negative battery cable. Refer to [Battery Negative Cable Disconnection and Connection](#).
13. Enable the SIR system. Refer to SIR [Disabling and Enabling](#).